

Terminator™ ZT-P-WP

Terminator™ ZT-C-P-WP

Thermostat Connection Kit

INSTALLATION PROCEDURES



For Thermostat Connection (1-2 Heating Cables) Applications
For Use With Parallel Heating Cables



Terminator™ ZT-(C)-P-WP

INSTALLATION PROCEDURES

The following installation procedures are guidelines for the installation of the Terminator ZT-P-WP & ZT-C-P-WP Kits.

Kit Contents . . .



Item	Quantity	Description						
1	1	Expediter Assembly Support Cap with O-Ring Threaded Grommet Compressor Grommet Support Base with O-Ring						
2	1	Junction Box Lid						
3	1	Junction Box Base with O-Ring & M25 Dust Cap						
4	1	Nut						
5	1	Banding						
6	1	Thermostat w/ Terminal Blocks <small>(Refer to terminal specifications for maximum allowable wire size)</small>						
		<table border="1"> <thead> <tr> <th>Thermostat Type</th> <th>Terminals</th> </tr> </thead> <tbody> <tr> <td>ZT-C-230 Vac</td> <td>4 mm² terminals</td> </tr> <tr> <td>ZT-C-400 Vac</td> <td>6 mm² terminals</td> </tr> </tbody> </table>	Thermostat Type	Terminals	ZT-C-230 Vac	4 mm ² terminals	ZT-C-400 Vac	6 mm ² terminals
Thermostat Type	Terminals							
ZT-C-230 Vac	4 mm ² terminals							
ZT-C-400 Vac	6 mm ² terminals							
7	1	Capillary Armouring w/ Glands						
8	1	Junction Box Cord						
9	1	Blind Plug						
10	1	Bracket						
11	3	Screws						
12	3	Washers						

Order Separately . . .

PETK Power and End Termination Kits (per cable)

PETK-1 for RSX, VSX, VSX-HT, BSX

PETK-2 for KSX, HTSX, USX

PETK-3-ECM for HPT, FP

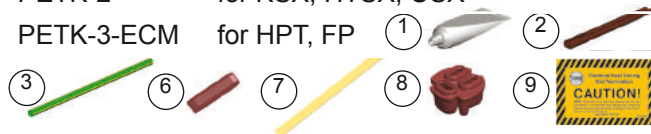

Item	Quantity	Description
1	1	RTV Tube
2	1	Power Connection Boot
3	1	Ground Sleeve
4	1	End Cap
5	1	Tape Strip (PETK-3-ZT only)
6	1	Grommet (PETK-3-ZT only)
7	1	End Termination Caution Label

IEK Insulation Entry Kit (per cable)

IEK-SXL: for RSX, VSX, VSX-HT

IEK-SXM for BSX

IEK-SXS for KSX, HTSX, USX

IEK-HPT for HPT, FP



Receiving, Storing and Handling . . .

1. Inspect materials for damage incurred during shipping.
2. Report damages to the carrier for settlement.
3. Identify parts against the packing list to ensure the proper type and quantity has been received.
4. Store in a dry location.

Dimensions . . .

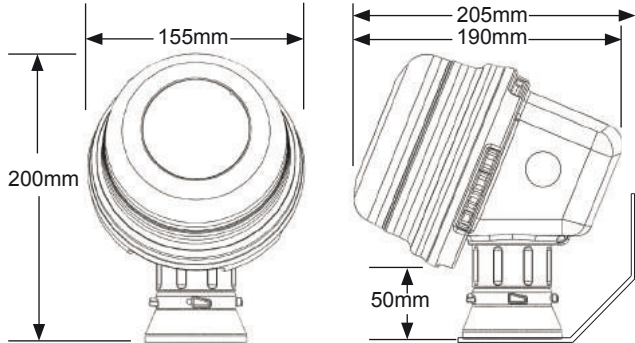

Warnings

- Due to the risk of electrical shock, arcing and fire caused by product damage or improper usage, installation or maintenance, a ground-fault protection device is required.
- Installation must comply with Thermon requirements (including form PN 50207U for Ex systems) and be installed in accordance with the regulations as per the norm EN IEC 60079-14 for hazardous areas (where applicable), or any other applicable national and local codes.
- Component approvals and performance ratings are based on the use of Thermon specified parts only.
- De-energize all power sources before opening enclosure.
- Avoid electrostatic charge. Clean only with a damp cloth.
- Keep ends of heating cable and kit components dry before and during installation.
- Minimum bending radius of heating cable is 32 mm (except HPT is 57 mm and FP is 19 mm).
- Individuals installing these products are responsible for complying with all applicable safety and health guidelines. Proper Personal Protective Equipment (PPE) should be utilized during installation. Contact TC-E if you have any additional questions.
- Consult the manufacturer for dimensional information on the flameproof joints for repair.

Tools Required



Certifications/Approvals

IP66; -60°C ≤ Ta ≤ +55°C T6, 85°C 16 Amps Max

-60°C ≤ Ta ≤ +50°C T5, 100°C 25 Amps Max

Ordinary & Hazardous Locations

Terminator ZT

FMG 10.0022X Ex db eb IIC T5-T6, Ex tb IIIC T100°C-T85°C

2809 II 2 GD Ex db eb IIC T5-T6, Ex tb IIIC T100°C-T85°C FM10ATEX0058X

Terminator ZT-C

EPS 19.0094X Ex db eb IIC T5-T6, Ex tb IIIC T100°C-T85°C

2809 II 2 GD Ex db eb IIC T5-T6, Ex tb IIIC T100°C-T85°C EPS 19ATEX1216X

Terminator™ ZT-(C)-P-WP INSTALLATION PROCEDURES

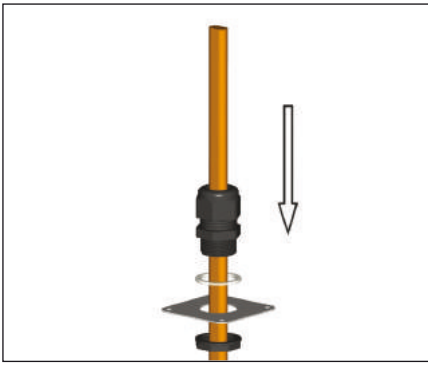

1. Slide appropriate IEK insulation entry kit components onto cable. (Order Separately)

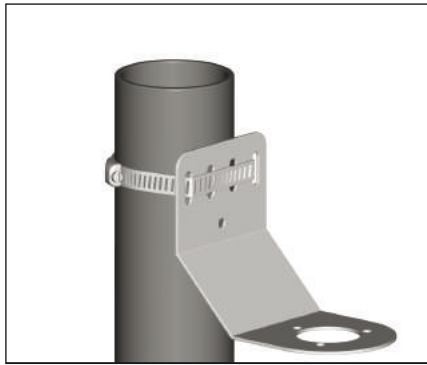

2a. Mounting Method 1: Secure wall mount bracket to mounting surface using pipe band provided with kits.

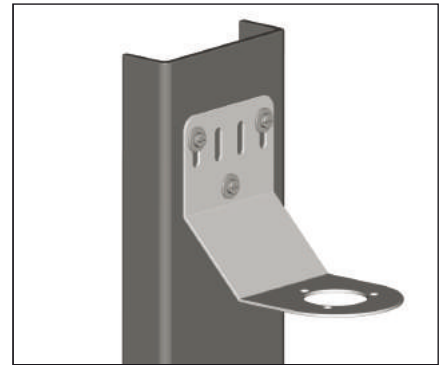

2b. Mounting Method 2: Secure wall mount bracket to mounting surface using customer supplied screws, flat washers, and nuts.

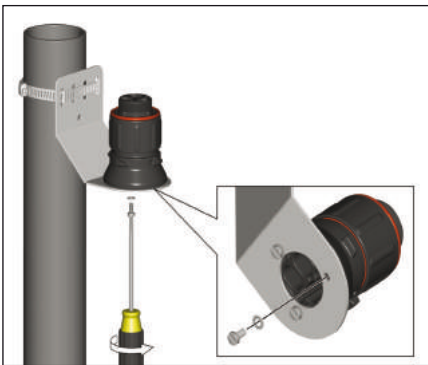

3. Mount expediter to bracket using M5 x 8 mm screws and M5 lock washers.

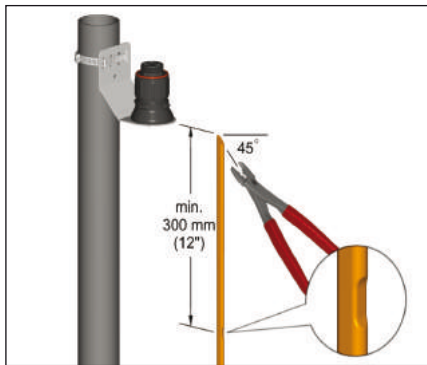

4. Locate bus connection (HPT and FP only) as shown. Cut end of cable at angle to aid in piercing grommet. Leave additional cable for expansion as needed.

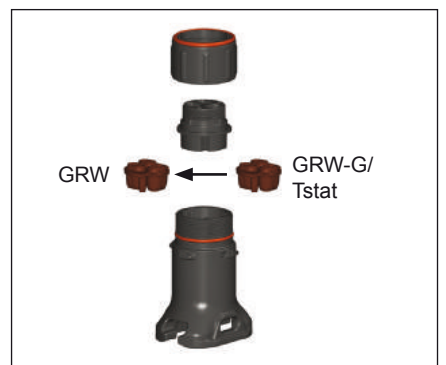

5. For HPT and FP cable, exchange grommet in Terminator with grommet provided in PETK-3-ZT.

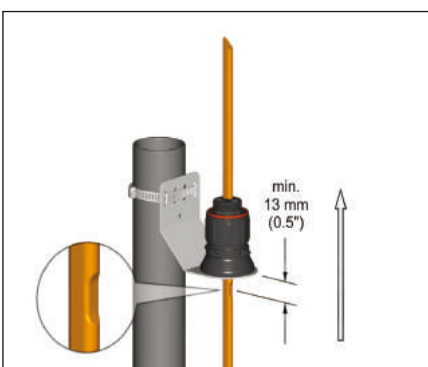

6. Insert cable into expediter. Make sure bus connection (HPT and FP only) remains outside of expediter.

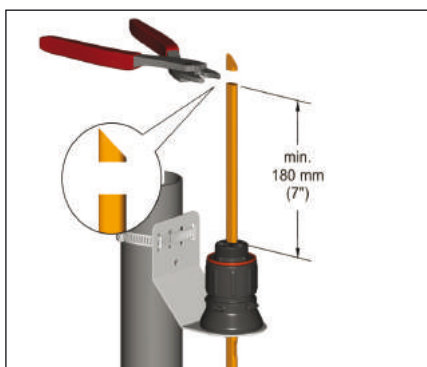

7. Cut off end of cable.

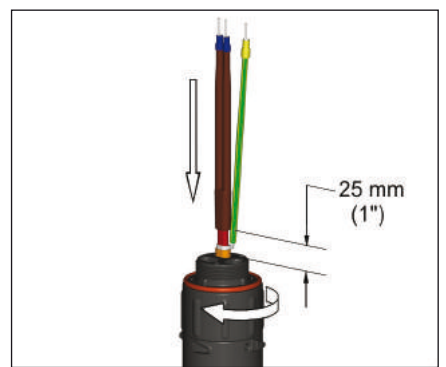

8. Terminate cable with appropriate PETK termination kit. Refer to PETK installation instructions. Push excess cable back through expediter. Tighten cap securely. Tape cable expansion loop to pipe.

Terminator™ ZT-(C)-P-WP INSTALLATION PROCEDURES

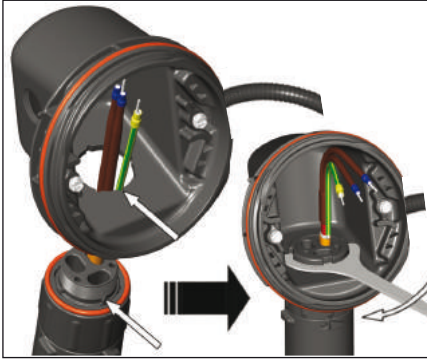

9. Mount junction box base on expediter. Make sure to align slots to properly orient junction box base. Tighten nut with Terminator-LN-Tool. If mounting horizontally, threaded gland holes must face downward.



10. Remove M25 dust cap. Install M25 power gland (order separately) and M25 blind plug. Install power cable

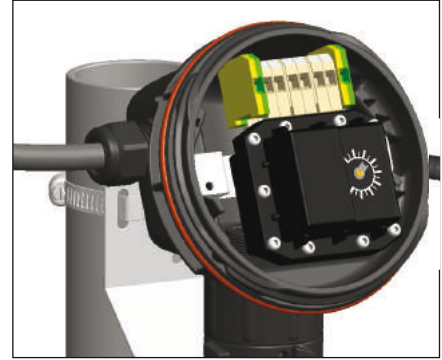

11. Install thermostat and complete system wiring. Terminal set screws shall be tightened to a torque value of 1.4 Nm (12.4 lb-in). See Step 13 for wiring details. Set thermostat at desired setpoint.

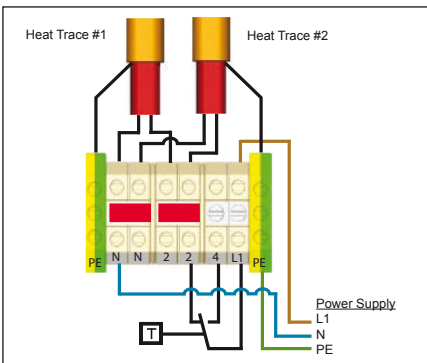

12. Wiring Details: Thermostat Connection (1 or 2 Heating Cables)

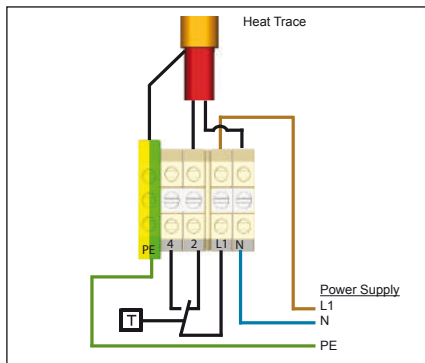

13. Thermostat Connection (1 Heating Cable Shown) 400 Vac Option.

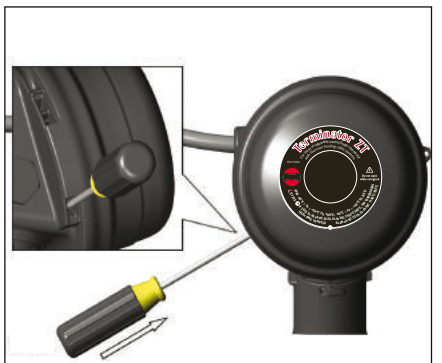

14. Install junction box lid and twist hand tight. Insert screwdriver into ratchet slots located on side of junction box base.



15. Use screwdriver to ratchet on junction box lid. Lid will rotate 30 degrees. To remove lid, repeat steps 14 and 15 but in the opposite direction.

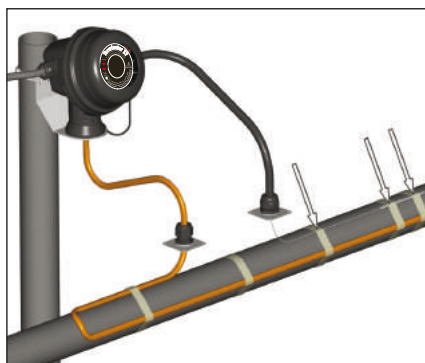

16. Fix thermostat bulb and capillary tube to pipe.

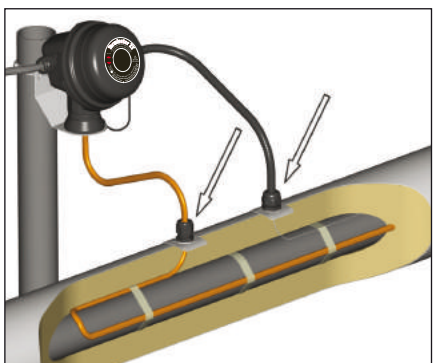

17. Install IEK insulation entry kit to seal heating cable penetration through insulation cladding.

