

Terminator™ ZT-C-Ambient

Thermostat Connection Kit

INSTALLATION PROCEDURES



Terminator™ ZT-C-Ambient

The following installation procedures are suggested guidelines for the installation of the Terminator ZT-C-Ambient Kit. For translations other than English and local language translation provided here, please contact Thermon. The English language installation procedure shall govern.

Kit Contents



Item	Quantity	Description
1	1	Wall Mount Assembly Support Cap with O-ring Threaded Grommet Compressor Grommet Support Base with O-ring Junction Box Base with O-ring 2xM25-blind & 1 Dust Cap Nut Thermostat with terminal Blocks Bracket (3x) M5 Screws & Lock Washers
2	1	Junction Box Lid
3	1	Banding
4	1	Junction Box Cord

Warnings

- Due to the risk of electrical shock, arcing and fire caused by product damage or improper usage, installation or maintenance, a ground-fault protection device is required.
- Installation must comply with Thermon requirements (including form PN 50207U for Ex systems) and be installed in accordance with the regulations as per the norm EN IEC 60079-14 for hazardous areas (where applicable), or any other applicable national and local codes.
- Component approvals and performance ratings are based on the use of Thermon specified parts only.
- De-energize all power sources before opening enclosure.
- Avoid electrostatic charge. Clean only with a damp cloth.
- Individuals installing these products are responsible for complying with all applicable safety and health guidelines. Proper Personal Protective Equipment (PPE) should be utilized during installation. Contact TC-E if you have any additional questions.
- Consult the manufacturer for dimensional information on the flameproof joints for repair.

Receiving, Storing and Handling

1. Inspect materials for damage incurred during shipping.
2. Report damages to the carrier for settlement.
3. Identify parts against the packing list to ensure the proper type and quantity has been received.
4. Store in a dry location.

Dimensions

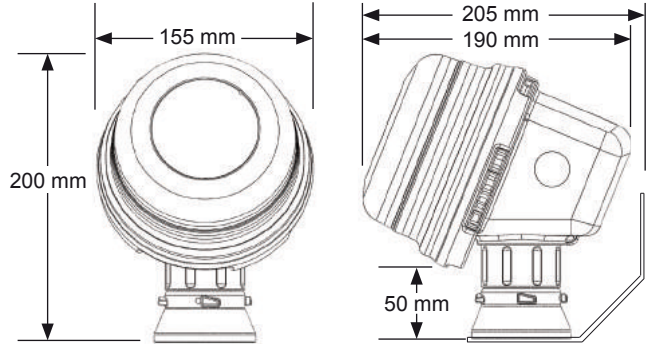

Tools Required



Certifications/Approvals

IP66 -60°C ≤ Ta ≤ +50°C
Ordinary & Hazardous Locations

In accordance with the EU ATEX Directive Certificate EPS 19ATEX1216X

International Electrotechnical Commission
IEC Certification Scheme for Explosive Atmospheres
IECEx EPS19.0094X

INSTALLATION PROCEDURES

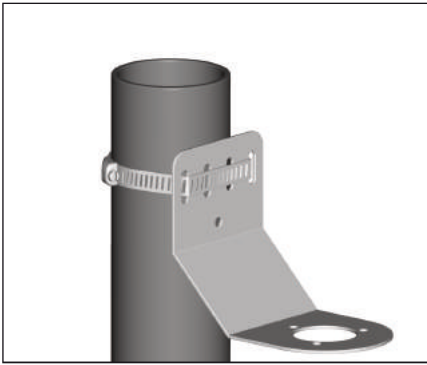

1a. Mounting Method 1: Secure wall mount bracket to mounting surface using pipe band provided with kits.

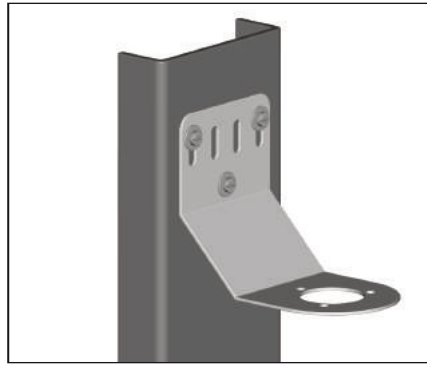

1b. Mounting Method 2: Secure wall mount bracket to mounting surface using customer supplied screws, flat washers, and nuts.

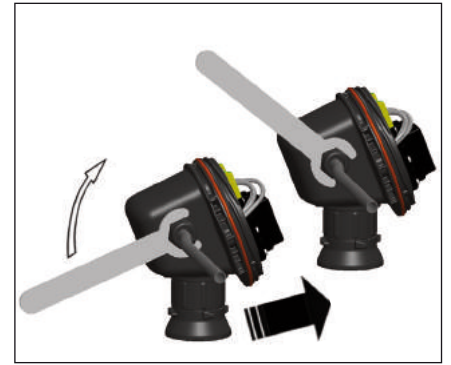

2. Remove M25 dust cap. Install M25 gland (order separately) blind plug. Install power/control cable.

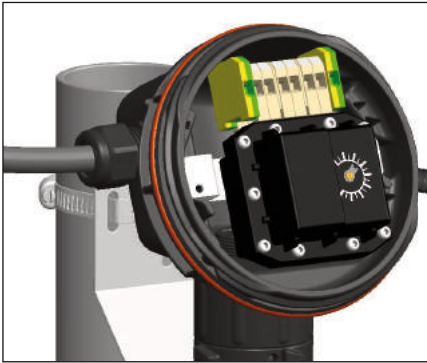

3. Install complete system wiring. Terminal set screws shall be tightened to a torque value of 1.4 Nm (12.4 lb-in). See Step 4 for wiring details. Set thermostat at desired set point (Winterization=5°C).

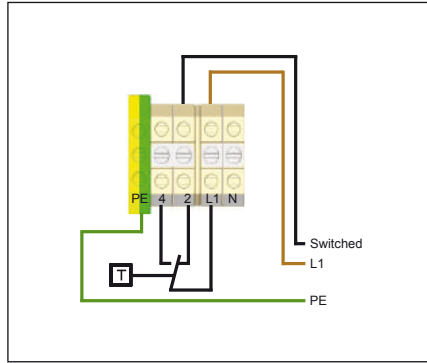

4. Wiring Details: Thermostat Connection.

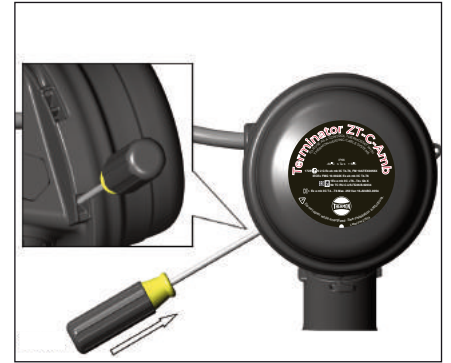

5. Install junction box lid and twist hand tight. Insert screwdriver into ratchet slots located on side of junction box base.



6. Use screwdriver to ratchet on junction box lid. Lid will rotate 30 degrees. To remove lid, repeat steps 14 and 15 but in the opposite direction.



TC-E B.V. · Buitendijks 37 · 3356 LX Papendrecht · The Netherlands · Tel: +31 (0) 183-20 10 88 · E-mail: sales@tc-e.nl · www.tc-e.nl

Form PN50874U-1220

© Thermon, Inc. · Printed in U.S.A. · Information subject to change.