



PRODUCT DATASHEET

TRACENET™ ECM™ -AMBIENT

ELECTRONIC CONTROL MODULE

APPLICATION

The TraceNet ECM-Ambient thermostat is designed to provide ambient sensing control of electric heat tracing circuits for freeze protection of piping and vessels. This thermostat can be used to control a heating circuit or as pilot control of a contactor switching multiple heat tracing circuits¹. The ECM-Ambient provides energy savings and precise control for heat trace circuits.

The ECM is housed in a glass reinforced nonmetallic enclosure with an environmental protection rating of IP66. Rotary switches are provided for adjusting temperature control and limiter set points. The standard version of the ECM communicates on a physical network of RS485 by using a Mod-bus RTU communication protocol.

The ECM-Ambient is approved for use in both ordinary (non-classified) and hazardous (classified) areas.

RATINGS

Operating/control voltage
 120 Vac +10%/-10% (50/60 Hz)
 230 Vac +10%/-10% (50/60 Hz)
 Operating ambient range..... -60°C to 55°C
 Minimum ambient storage range -74°C
 Control switch type options..... SPST and DPST
 Switching current ratings²
 SPST 30/30/20 amps (25°C, 40°C, 55°C)
 DPST 28/23/17 amps (25°C, 40°C, 55°C)
 Alarm output current rating 2 A
 Electrical connection..... terminal blocks³
 Adjustable temp. control range..... 0° to 500°C
 Measurement range..... -60° to 500°C
 Measurement accuracy (ambient)..... ± 1°C (0°C to +55°C ambient)
 ± 2°C (0°C to -60°C ambient)
 Ambient temp. sensor(s)..... 100 Ohm three wire Platinum RTD
 RTD input circuitry intrinsically safe (EX i)
 Life expectancy 100,000 cycles

CERTIFICATIONS/APPROVALS

Certificate SIRA 12ATEX5239X
 II 2(2) G Ex eb mb [ib] IIC T4 Gb
 II 2(2) D Ex tb IIIC T135°C IP66 Db

Certificate IECEx SIR 12.0103X
 Ex eb mb [ib] IIC T4 Gb
 Ex tb IIIC T135°C Db

Canadian Standards Association
 Ordinary and hazardous (Classified) Locations

ECM Ambient has additional hazardous approvals including:
 TRCU, TCCE, INMETRO



CONSTRUCTION

- 1 Junction box, glass-reinforced polymer
- 2 Pipe-mount expeditor, glass-reinforced polymer
- 3 Ambient temperature sensor
- 4 Stainless steel mounting bracket

PRODUCT FEATURES

- Encapsulated electronics and control
- One temperature control module for wide range of temperature control
- Energy saving accurate electronic temperature control action
- Data highway communication capability
- Control in degrees Centigrade or degrees Fahrenheit
- Combines power junction box and control module in one unit

Notes

1. Standard configuration is pilot control of a contactor switching multiple heat tracing circuits. When the thermostat is used to switch other types of heating cable, please contact TC-E.
2. When located outdoors and subject to solar gain, some current de-rating will be required. Contact TC-E for additional information.
3. The terminal blocks consist of:
 (6) 10 mm² line/load/PE terminals
 (3) 3 mm² comm. port terminals
 (3) 3 mm² alarm relay terminals
 (2 x 3) 2.5 mm² sensor terminals
 See installation instructions for maximum wire size.
4. Refer to Form TEP0010U, System Accessories - Heat Tracing Cables for additional accessories.



PRODUCT DATASHEET
TRACENET™ ECM™-AMBIENT
 ELECTRONIC CONTROL MODULE

PRODUCT REFERENCE LEGEND

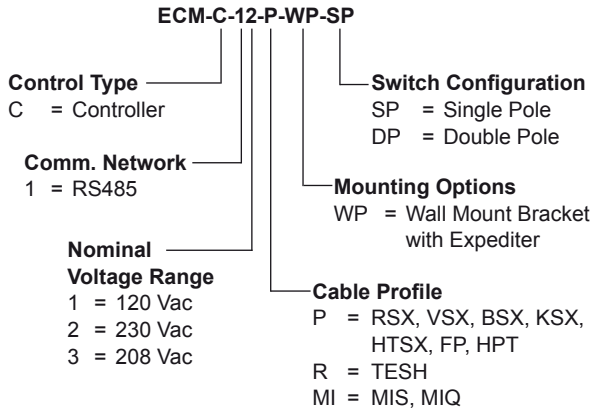

TYPICAL WIRING DIAGRAM (for controller with limiter)

Single Pole

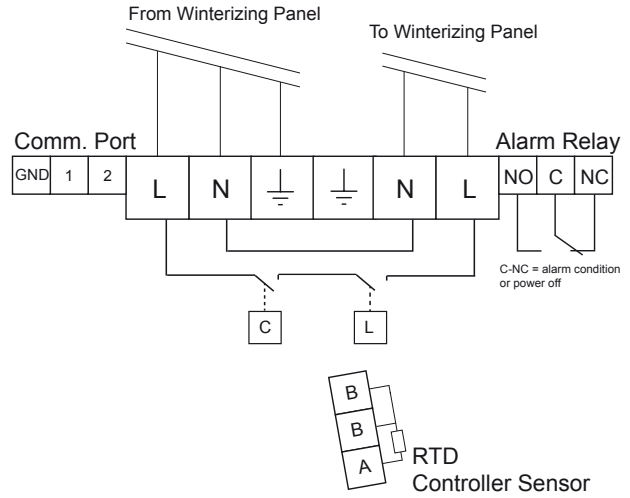

Double Pole

