

Installation Instructions

UAS Single Entry Power Connection Kit

with Integral Thermostat for Self-Regulating
& Constant Wattage Heating Cables



PJ943-1
161-562581-038
April, 2021

UAS Single Entry Power Connection Kit

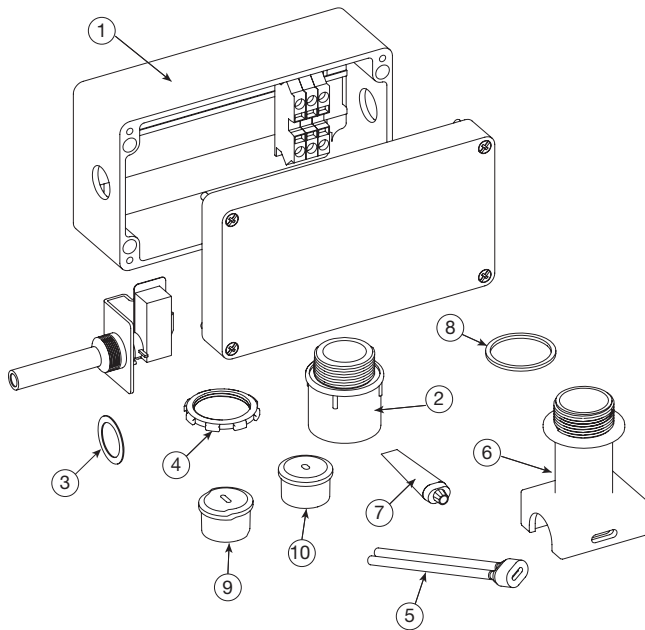

Item	Qty	Description
1	1	Junction box with Ambient Sensing Thermostat
2	1	Compression fitting
3	1	Washer for Thermostat
4	1	Locknut
5	1	Silicone termination boot
6	1	Pipe standoff
7	1	RTV
8	1	O-Ring
9	1	Self-regulating cable grommet (Black)
10	1	Constant wattage cable grommet (Orange)

General

The UAS Single entry power connection kit/ with integral thermostat is used for electrical termination of selfregulating and constant wattage cables. Each kit contains the terminations needed to make all electrical connections.

Certifications & Approvals

IP66 NEMA/Type 4X -60°C < Ta < +55°C
Ordinary Areas



Installation

⚠ WARNING

HAZARD OF ELECTRIC SHOCK. Disconnect all power before starting. All installations must be effectively grounded in accordance with the National Electrical Code to eliminate shock hazard.

⚠ WARNING

Turn off power before removing junction box cover at all times.

⚠ WARNING

Users should install adequate controls and safety devices with their electric heating equipment. Where the consequences of failure may be severe, back-up controls are essential. Although the safety of the installation is responsibility of the user, Chromalox will be glad to assist in making equipment recommendations.

Braid only cable instructions SRL-C, SRM/E-C, CWM-C cable special instructions denoted by *

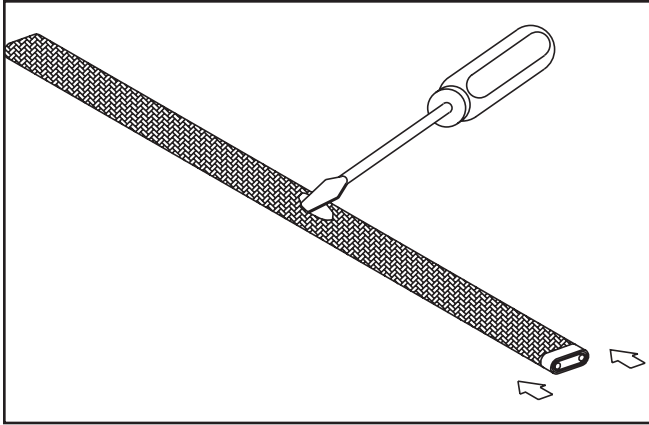

1. For each cable, push braiding back from the end of the cable. 11" from cable end create a bulge. At the bulge, separate the braid to make an opening.

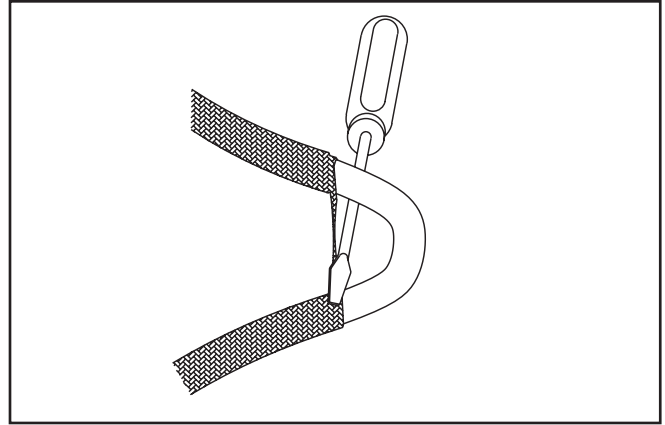

2. While bending the heating cable, work the cable through the braid opening. Pull the braid tight.

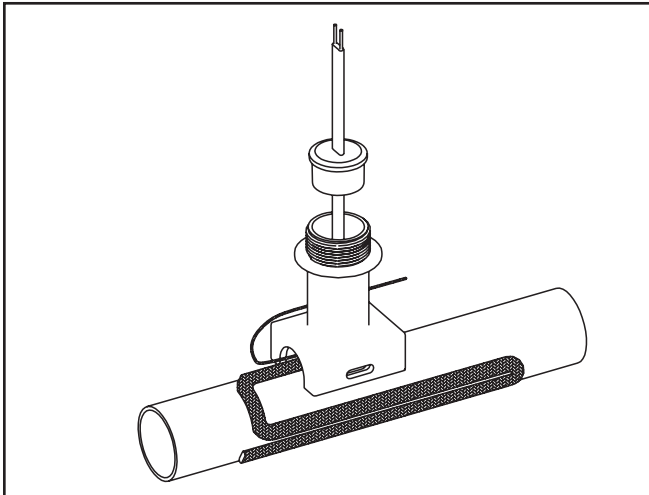

3. Insert cable through pipe standoff and grommet as shown. There should be 8" of cable past the grommets edge. Attach the pipe standoff to the pipe with a pipe strap (Chromalox type PS not included) as shown. Leave braid of the cable outside of pipe standoff and connect to ground (grounding clamp not included). Tape cable pipe as shown. For pipes smaller than 1 1/2" diameter a small pipe adapter (Chromalox model SPA not included) is required.

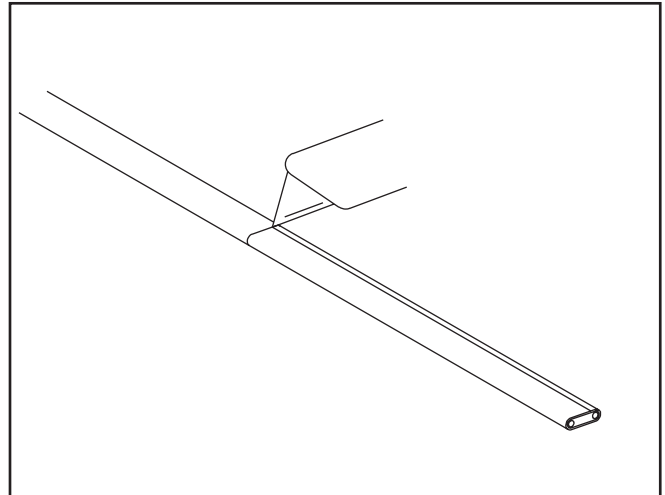

4. Score the inner insulation 7" from the end. Lightly cut the inner jacket up the center to end of heating cable and remove the inner jacket from the cable.

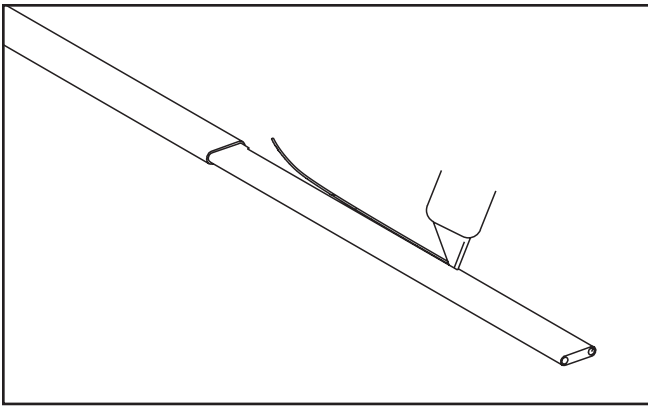

- 5.** Shave the core material from the outside of each bus wire.
 *Skip this step if using CWM-C constant wattage cable.

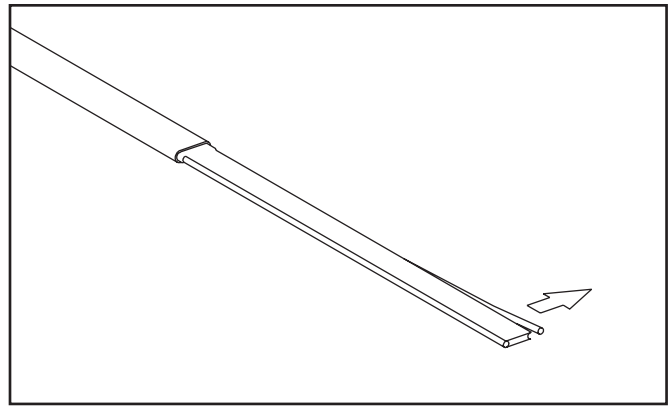

- 6.** Starting at the end of the heating cable, using needle nose pliers or a knife, pull each bus wire away from the core material.
 *Separate CWM-C leads and strip 1/4" from each leadwire.

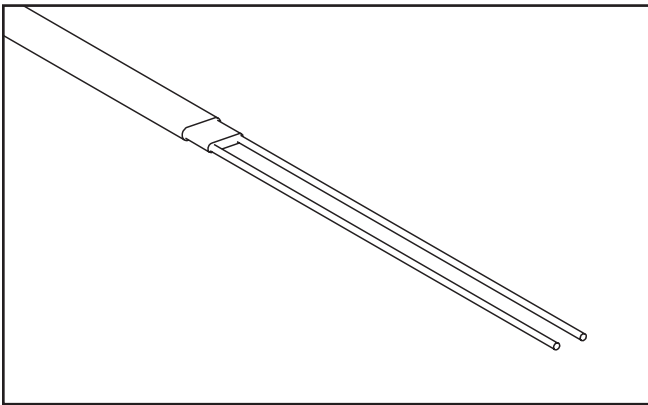

- 7.** Remove the exposed core material and cut 1/4" off the end of each bus wire. *Skip this step if using CWM-C constant wattage cable.

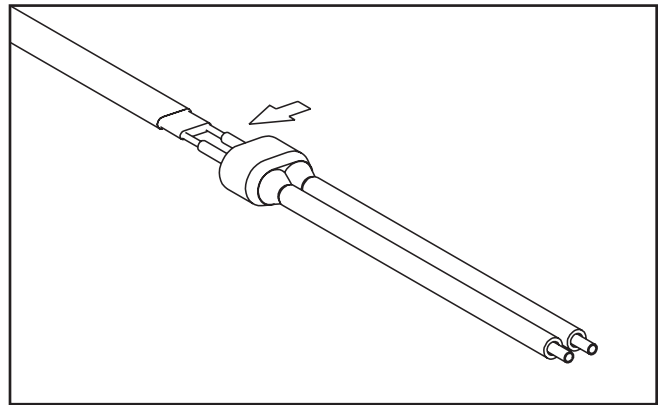

- 8.** Liberally apply RTV over the exposed matrix and leads. Push the rubber boot over the heating cable. Trim lead ends as needed.
 *Boot is not needed when using CWM-C constant wattage cable..

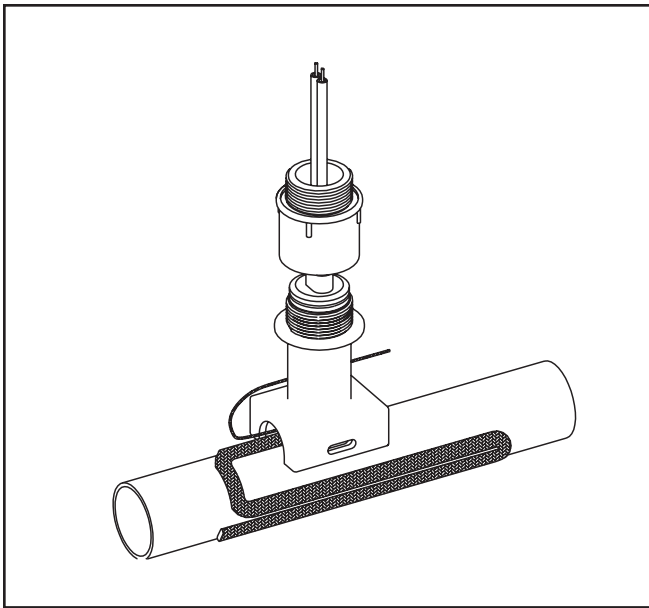

9. Slide compression fitting over cable. Grommet should be placed inside pipe standoff. Termination boot should be spaced 1/2" from sealing grommet. Tighten compression fitting until it bottoms out against pipe standoff.

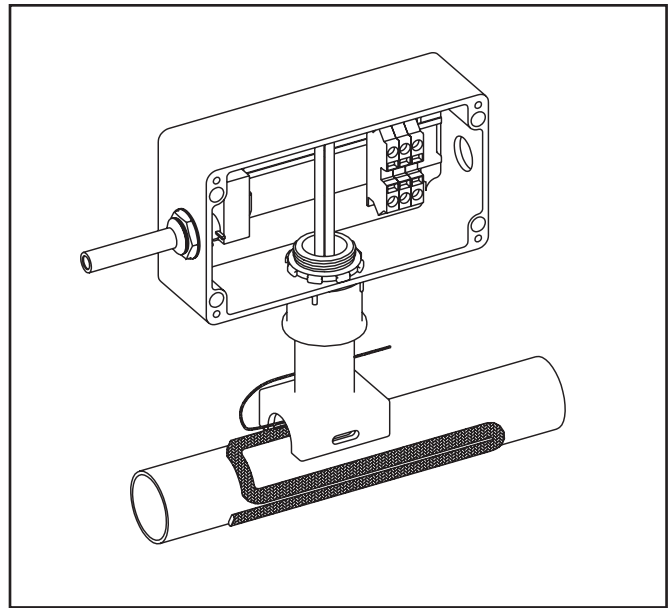

10. Assemble junction box to compression fitting as shown. Tighten locknut until the junction box bottoms out against the lip of the compression fitting. To ensure that box is water tight make sure washer for thermostat is against the enclosure.

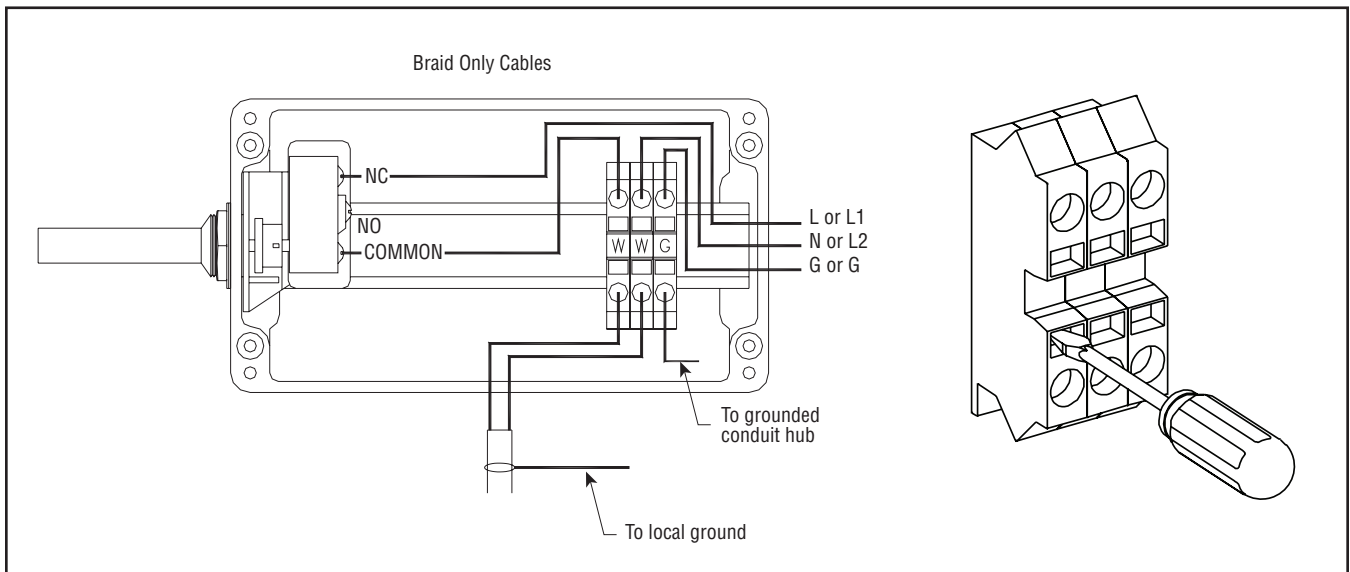

11. Attach 3/4" conduit hub. Use a flat head screwdriver to release the terminal spring clamps and insert cable leads and grounding braid. Please see the electric diagrams below for proper wiring for your application. Attach junction box cover to seal enclosure. Note: The conduit hub should be approved for Class 1, Div. 2; Class II Div. 1 & 2, Class III, Div. 1 & 2, and NEMA 4X rated by a nationally recognized testing laboratory.

Overjacketed cable instructions SRL-CR, SRL-CT, SRM/E-CT, CWM-CT cable instructions denoted by *

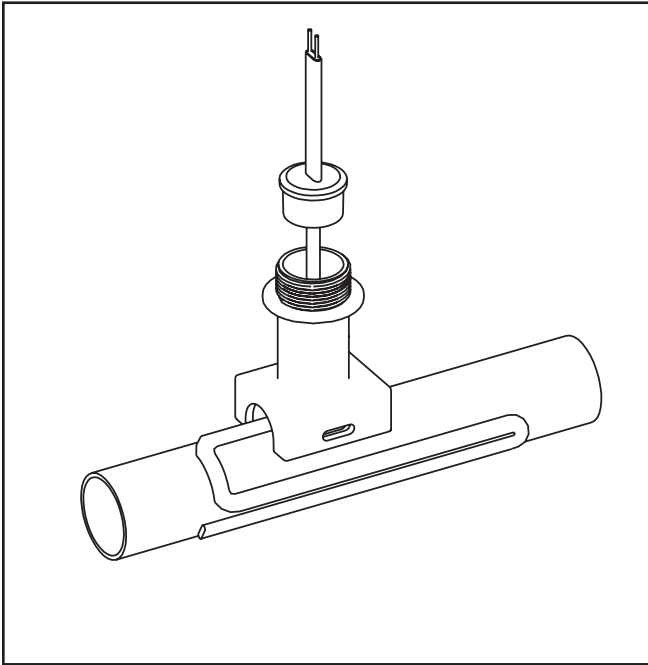

1. Insert heating cable and grommet as shown. 8" of cable should extend past the grommet. Attach the pipe standoff to the pipe with a pipe strap (Chromalox type PS not included) as shown. Attach extra cable to pipe as appropriate. For pipes smaller than 1-1/2" diameter optional small pipe adapter (Chromalox model SPA not included) is required.

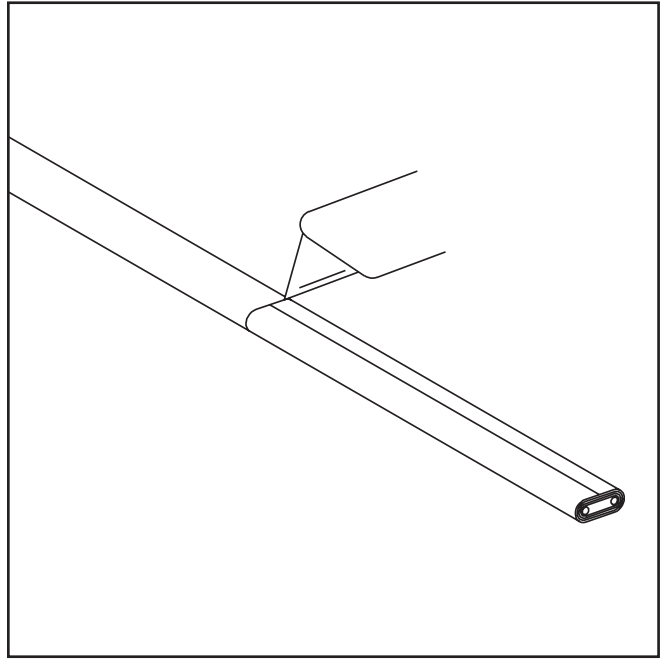

2. Score the outer insulation 7" from the end of the cable. Lightly cut the outer jacket up the center to the end of heating cable and remove the outer jacket from the cable. **WARNING: DO NOT CUT METAL BRAID.**

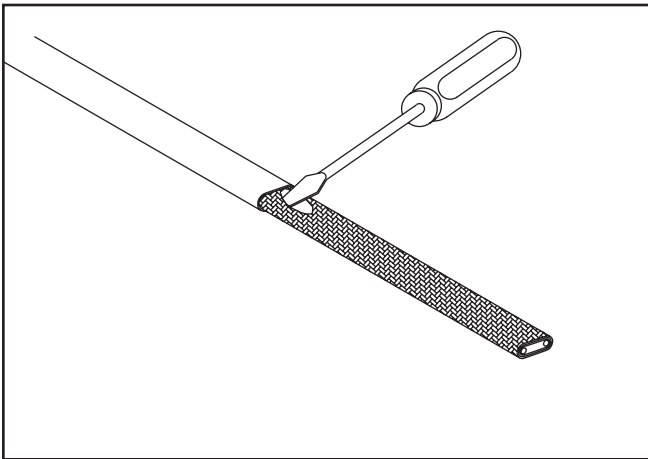

3. Move braid back toward the overjacket, creating a bulge. At the bulge, separate the braid to make an opening.

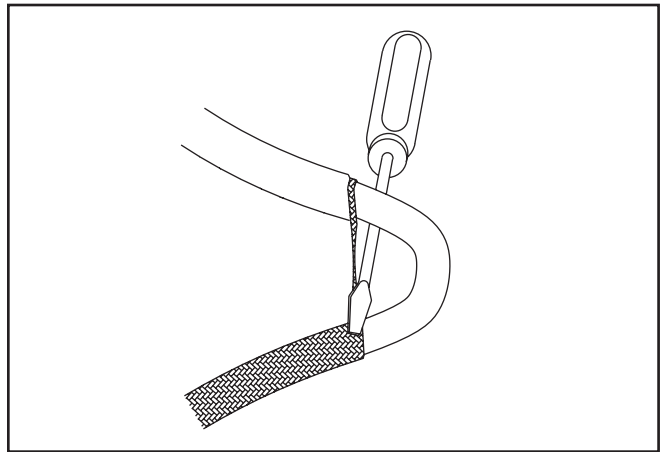

4. While bending the heating cable, work the cable through the braid opening. Pull the braid tight.

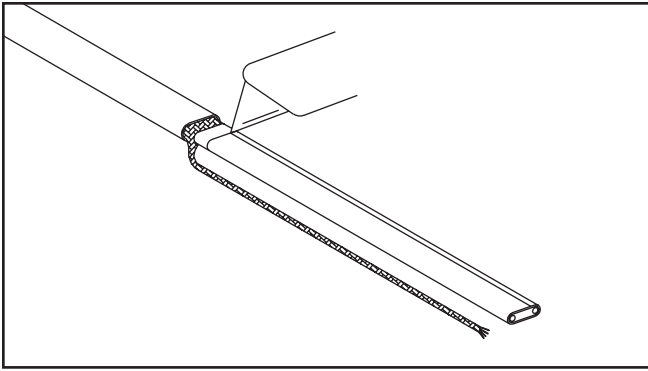

5. Score the inner insulation 6" from the end. Lightly cut the inner jacket up the center to end of heating cable and remove the inner jacket from the cable.

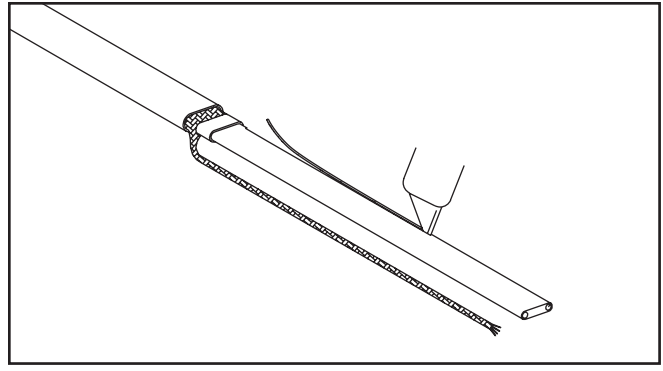

6. Shave the core material from the outside of each bus wire.
*Skip this step if using CWM-C constant wattage cable.

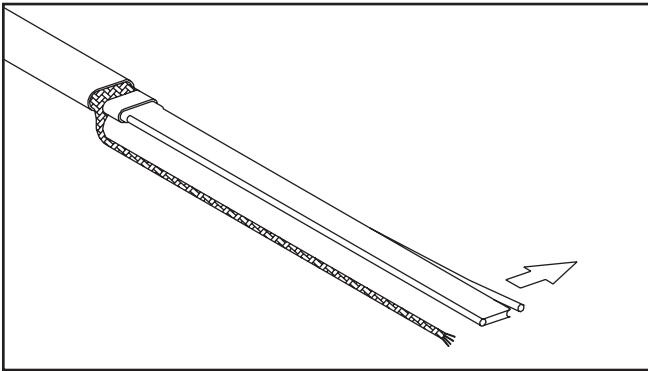

7. Starting at the end of the heating cable, using needle nose pliers or a knife pull each bus wire away from the core material.
*Separate CWM-C leads and strip 1/4" from each leadwire.

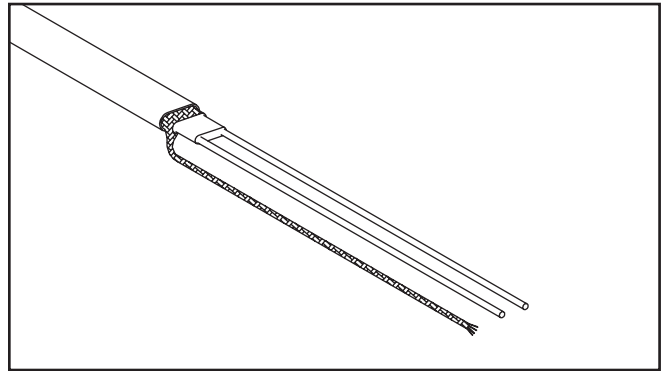

8. Remove the exposed core material and cut 1/4" of the end of each bus wire. *Skip this step if using CWM-C constant wattage cable.

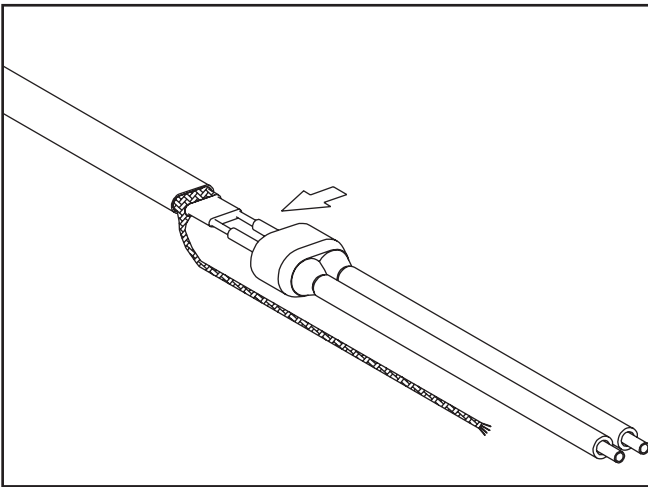

9. Liberally apply RTV over the exposed matrix and leads. Push the rubber boot over the heating cable. Trim lead ends as needed.
*Boot is not needed when using CWM-C constant wattage cable.

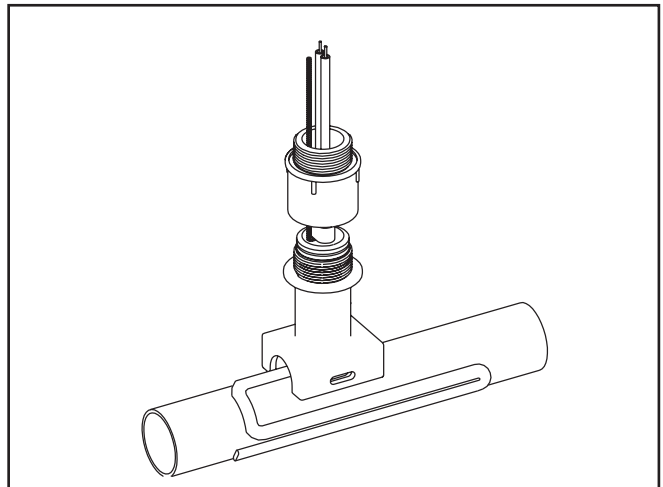

10. Slide compression fitting over cable. Grommet should be placed inside pipe standoff. Termination boot should be spaced 1/2" from sealing grommet. Tighten compression fitting until it bottoms out against pipe standoff.

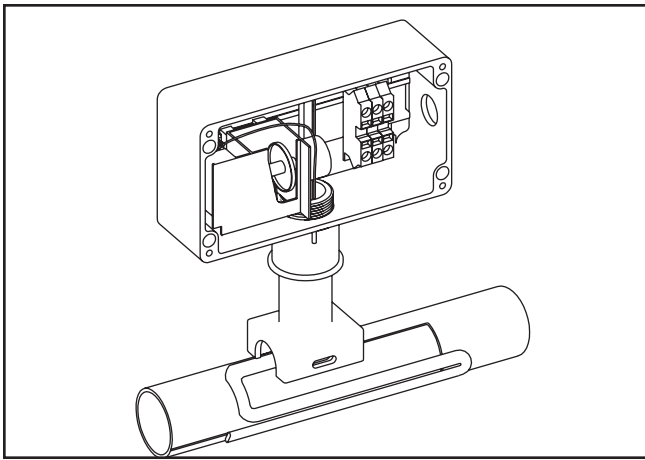

- 11.** Assemble junction box to compression fitting as shown. Tighten locknut until the junction box bottoms out against the lip of the compression fitting. To ensure that box is water tight make sure washer for thermostat is against the enclosure.

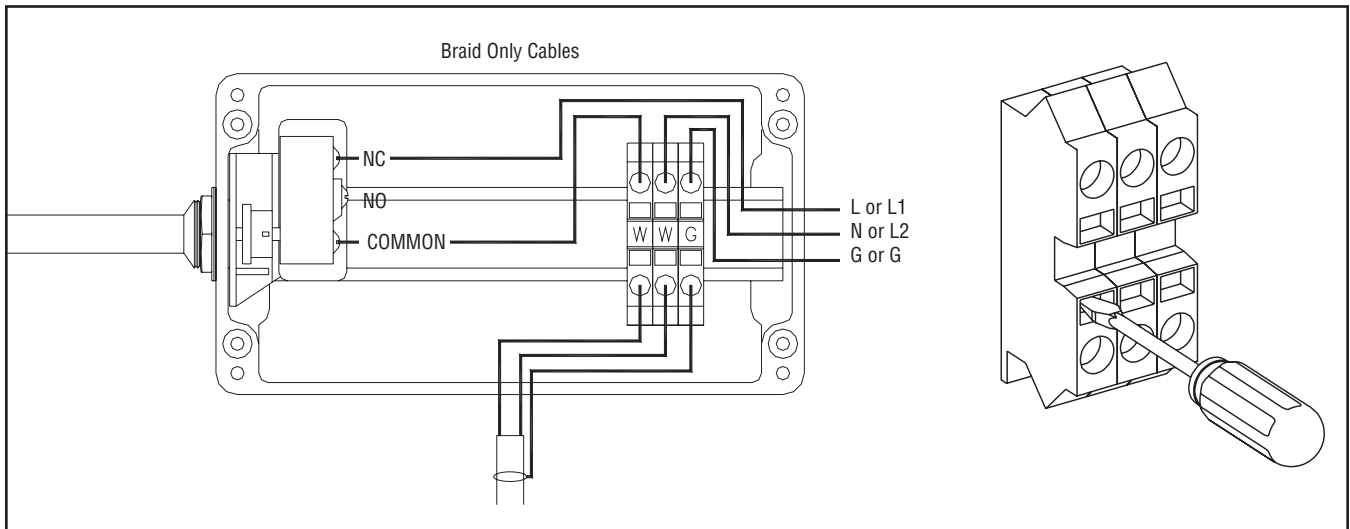

- 12.** Attach 3/4" conduit hub. Use a flat head screwdriver to release the terminal spring clamps and insert cable leads and grounding braid. Please see the electric diagrams below for proper wiring for your application. Attach junction box cover to seal enclosure. **NOTE:** The conduit hub should be approved for Class 1, Div. 2; Class II Div. 1 & 2, Class III, Div. 1 & 2, and NEMA 4X rated by a nationally recognized testing laboratory.

Limited Warranty:

Please refer to the Chromalox limited warranty applicable to this product at <http://www.chromalox.com/customer-service/policies/termsofsale.aspx>.

Chromalox
103 Gamma Drive
Pittsburgh, PA 15238
(412) 967-3800
www.chromalox.com