



LINK™



a degree above | www.Thermon.com

Commercial Heat Trace Splice, Power Connection, and End Seal

INSTALLATION PROCEDURES

for **BSX™**, **DLX™**, **FLX™**, and **RGS™** Heat Tracing



The following instructions are guidelines for the installation of Thermon's **LINK** connection systems. They are not intended to preclude the use of other methods and good engineering or field construction practices.

Kit Contents

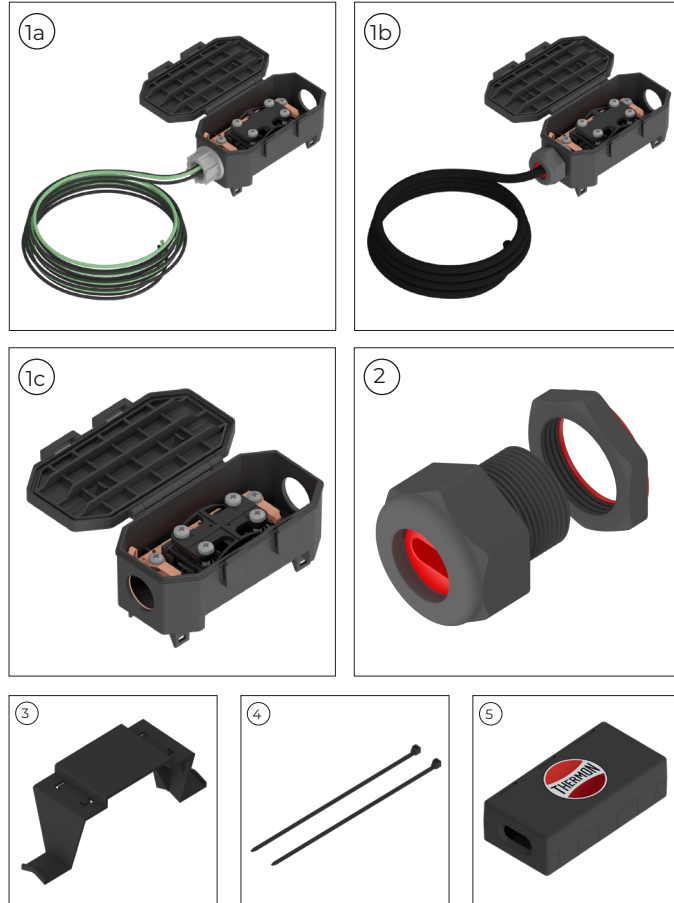

ITEM	QUANTITY	DESCRIPTION
1a	1	LINK-*-PC (Note 1) Enclosure & IDC Assembly Power Connection (Conduit Fitting) x Heat Trace Splice
1b	1	LINK-*-PF (Note 1) Enclosure & IDC Assembly Power Connection (Flexible Cable) x Heat Trace Splice
1c	1	LINK-X-HS (Note 1) Enclosure & IDC Assembly Heat Trace Splice
2	1 (or 2 for Splice kit)	M25 Cable Gland (fits "B" or "D" sized heat trace)
3	1	Optional mounting bracket
4	2	Zip tie
5	1 (or 0 for Splice kit)	LINK-X-ES End Seal

Note 1: * = B for BSX (OrdLoc), FLX, and RGS heat trace; * = D for DLX heat trace

Certifications/Approvals



Receiving, Storing and Handling

1. Inspect materials for damage incurred during shipping.
2. Report damages to the carrier for settlement.
3. Identify parts against the packing list to ensure the proper type and quantity has been received.

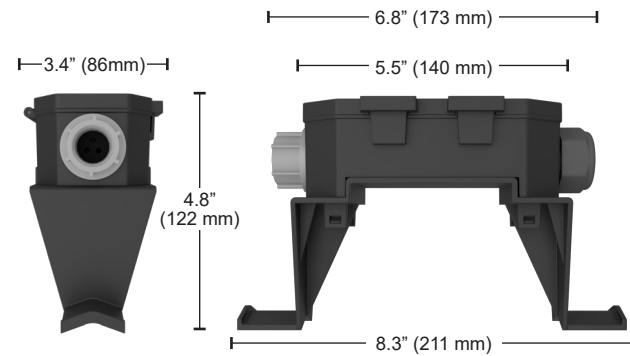

Installation Precautions

- To minimize the potential for arcing and fire caused by product damage or improper installation use ground-fault protection. The National Electrical Code (NEC) and Canadian Electrical Code (CEC) require ground-fault protection of equipment for each branch circuit supplying electric heat tracing.
- Installation must comply with Thermon requirements and be installed in accordance with the NEC, CEC, or any other applicable national and local codes. For UL compliant heat tracing systems, a UL Listed conduit and junction box must be used to terminate heat tracing circuits.
- De-energize all power sources before opening enclosure.
- Keep ends of heating cable and kit components dry before and during installation.
- Component approvals and performance ratings are based on the use of Thermon specified parts only. User supplied power connection fittings must be listed or certified for intended use.
- The kit instructions should be used in conjunction with the installation instructions for the heating cable and other accessory items.



INSTALLATION PROCEDURES

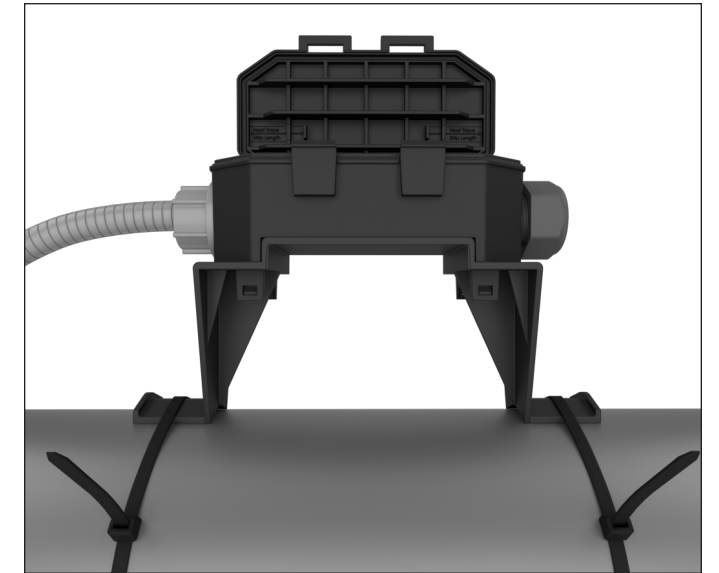
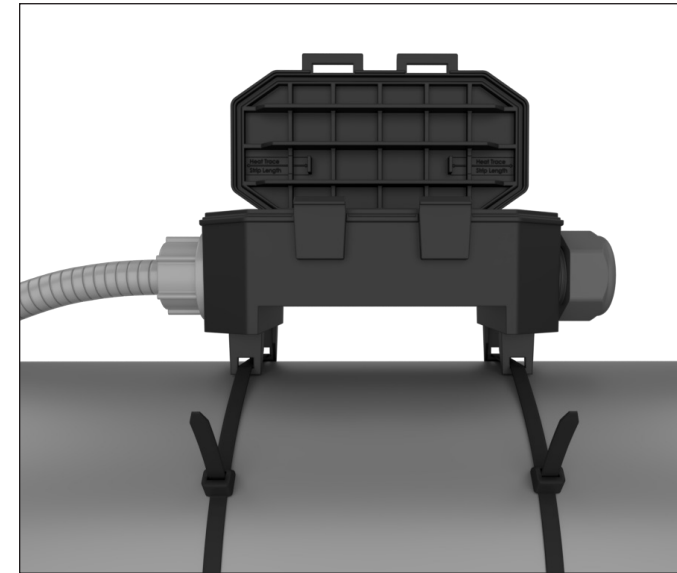

1. Place housing on pipe and secure with the zip ties. If using a "PC" kit, connect 1/2" conduit (user provided) to the 1/2" conduit fitting on the enclosure, ensuring not to exceed 18 Nm of torque. If using a "PF" kit, the **LINK** will include a flexible power cable instead of conduit fitting (see Kit Contents, Image 1b). If using an "HS" kit, the **LINK** will have heat trace glands on both sides (see Kit Contents, Image 2).
2. For installations where higher height is required to allow the enclosure to be accessible above the insulation, clip housing into bracket. Place bracket on pipe and secure with the zip ties.

WARNING: do not connect the power wires to the power supply terminals (user provided) until installation of the **LINK** is complete.



3. Cut off the end of the heat trace cable, in order to ensure that it is clean and straight..
4. Using the template provided on the underside of the lid or a printout, measure and mark cut length.

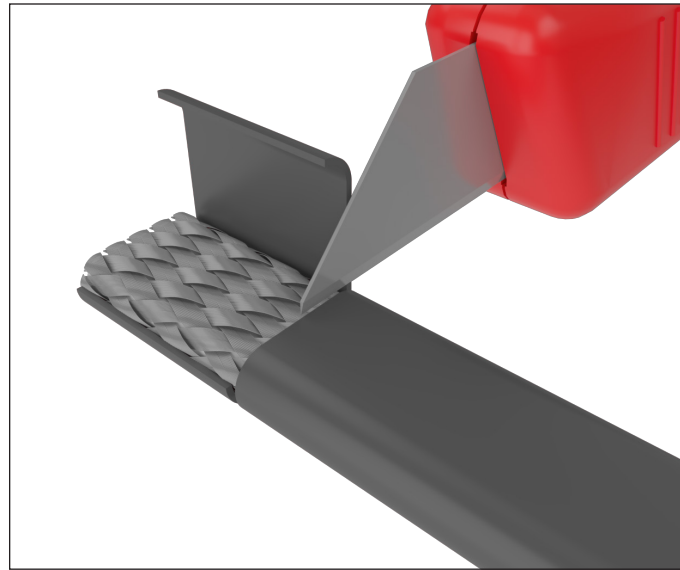

5. Cut and remove heating cable overjacket, being careful not to cut into the braid.

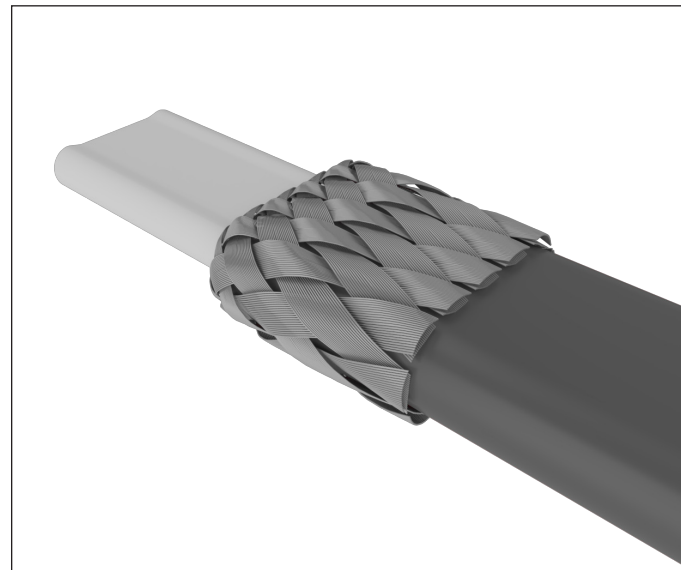

6. Pull back braid strands

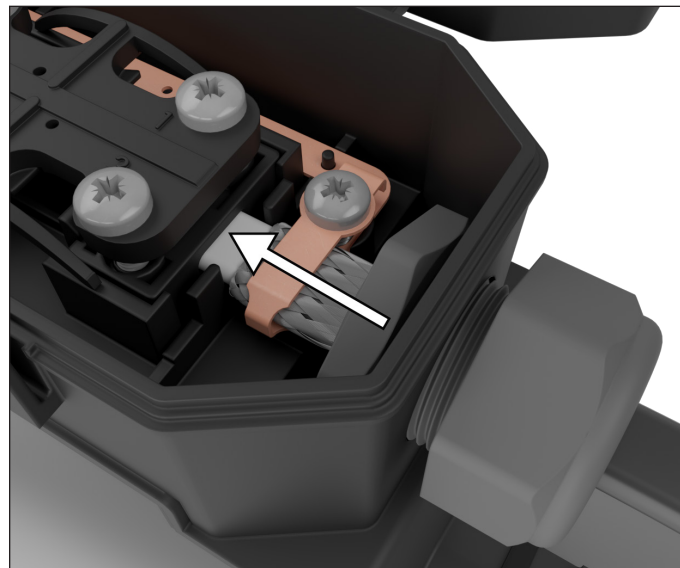

7. Insert cable into gland side entry until cable dead ends on inner housing rib.

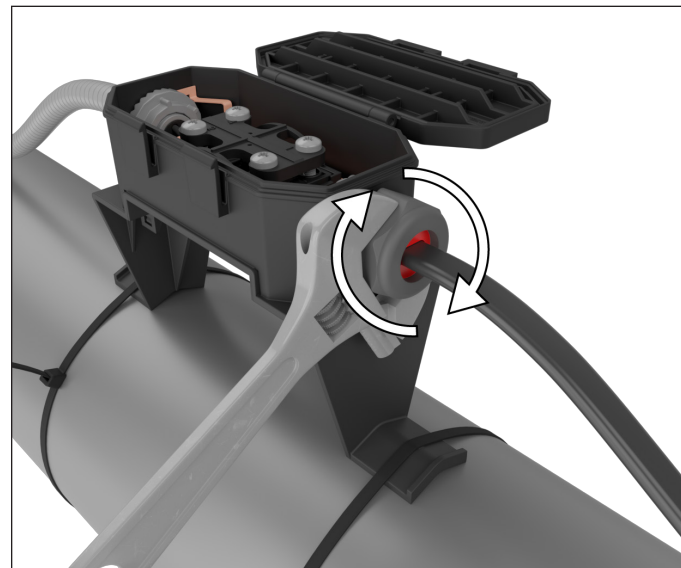

8. Torque gland nut (8 Nm for "LINK-B" version, 5 Nm for "LINK-D" version) to seal around cable.

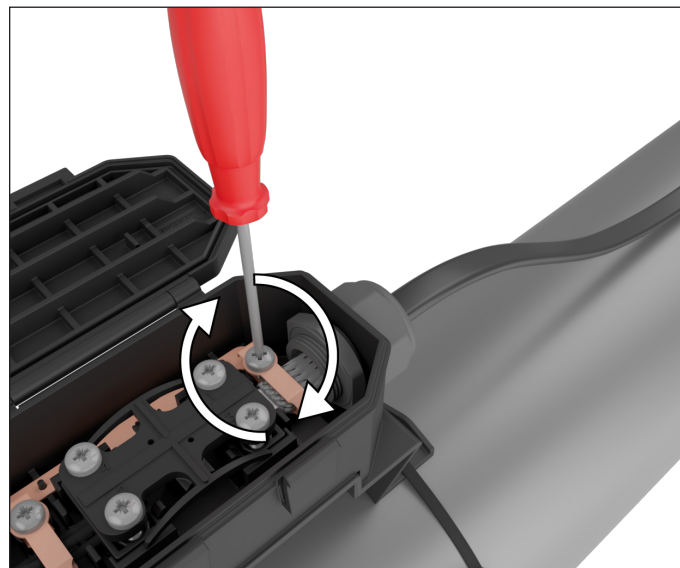

9. Screw down grounding bar around cable to 2 Nm.

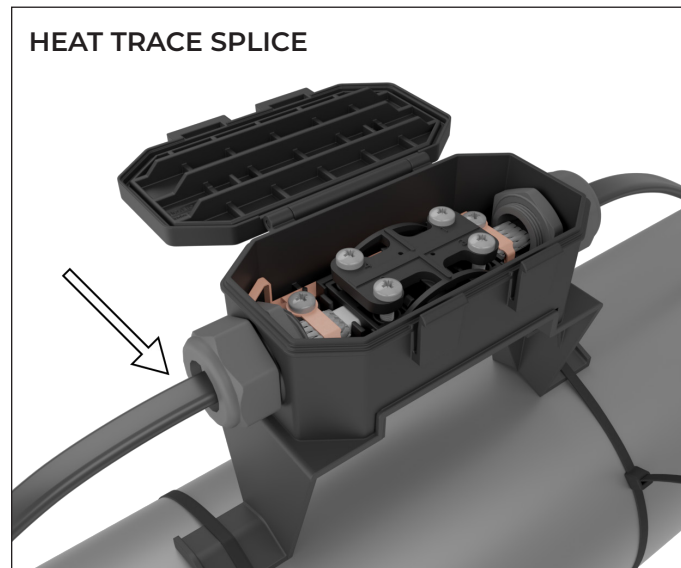

10. If connecting a splice, repeat steps 3-9 on the other side.

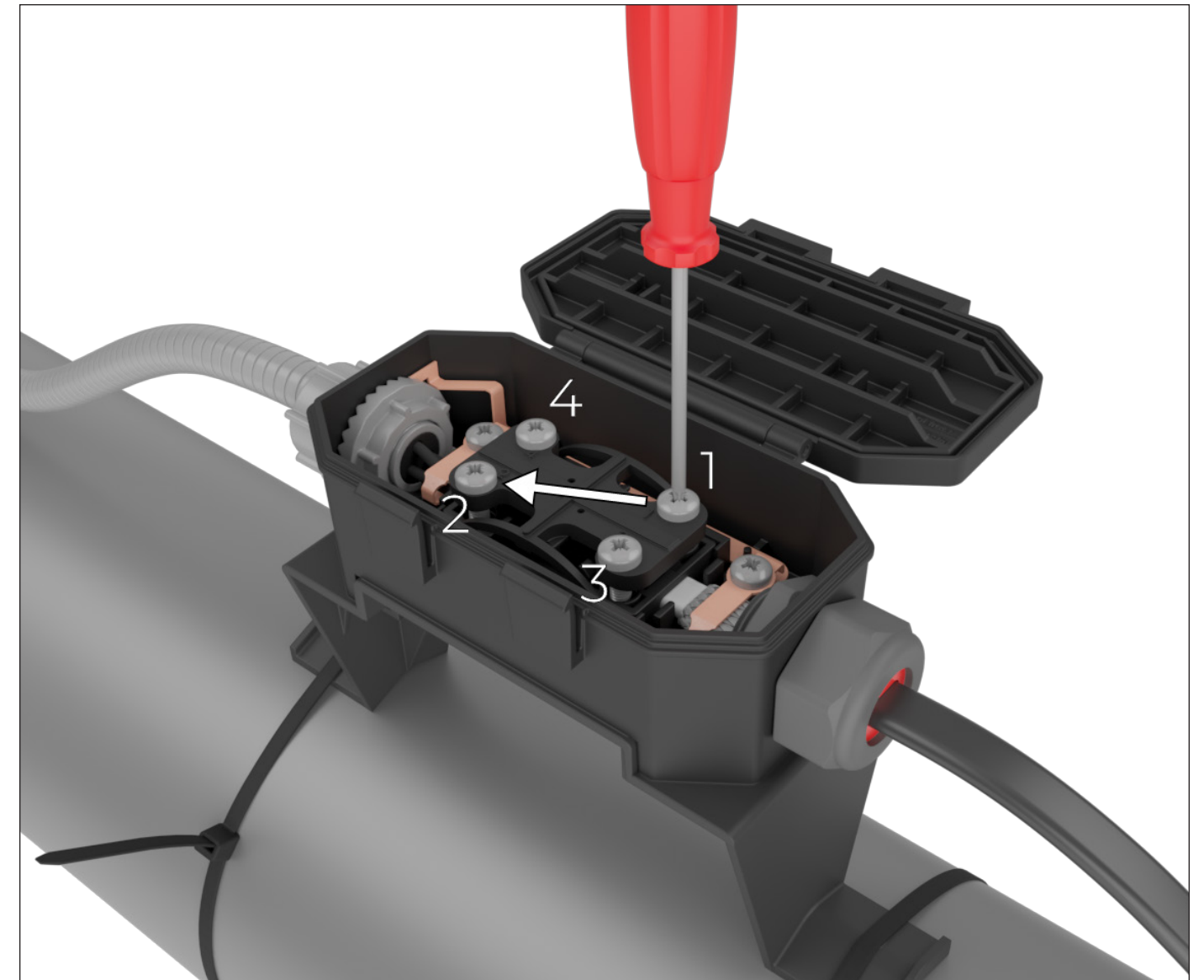

11. Starting with the screw labeled "1", and using an "X" pattern, tighten each screw approximately halfway down. Then repeat the "X" pattern until the IDC is fully seated with a torque of 2 Nm on each screw.

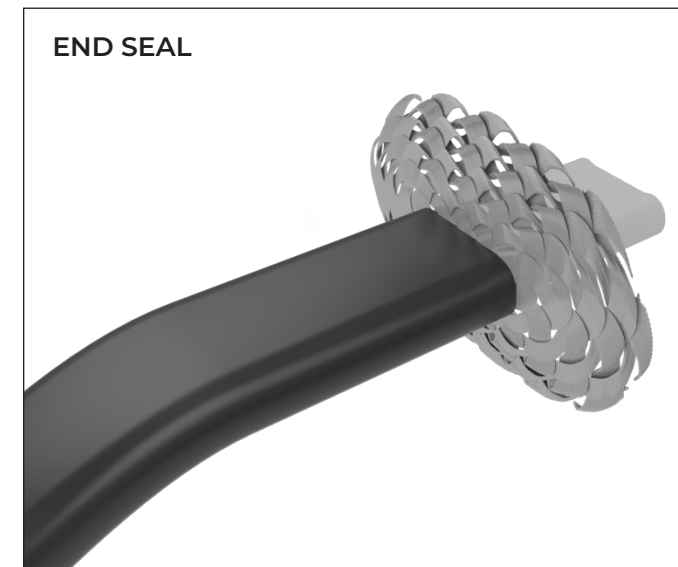

12. For installing an end seal, repeat steps 3-5 on the opposite end of the heat trace cable from the enclosure, and then pull the braid away from the cable.

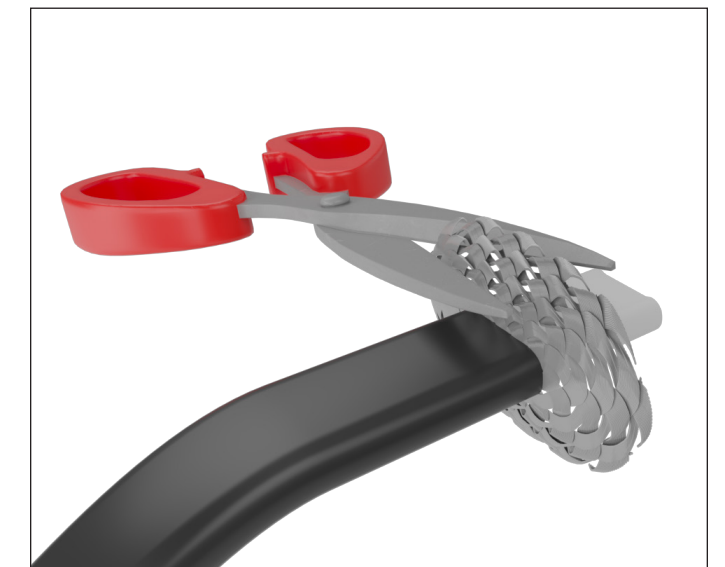

13. Trim away the exposed braid from the heat trace cable.



14. Push the end seal onto the heat trace cable until the overjacket is fully contained within the end seal.

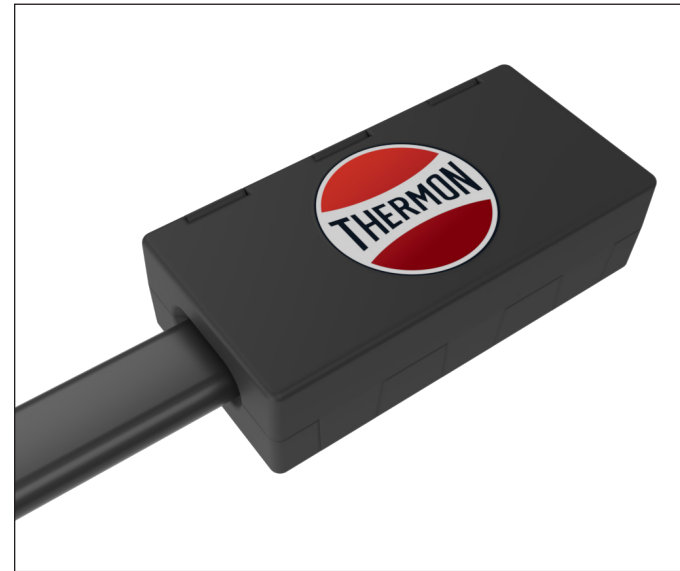

15. The end seal is single use, do not attempt to remove once installed.



17. Close the lid, ensuring that both snaps are fully secured.

WARNING: Do not close the lid until all steps have been completed.

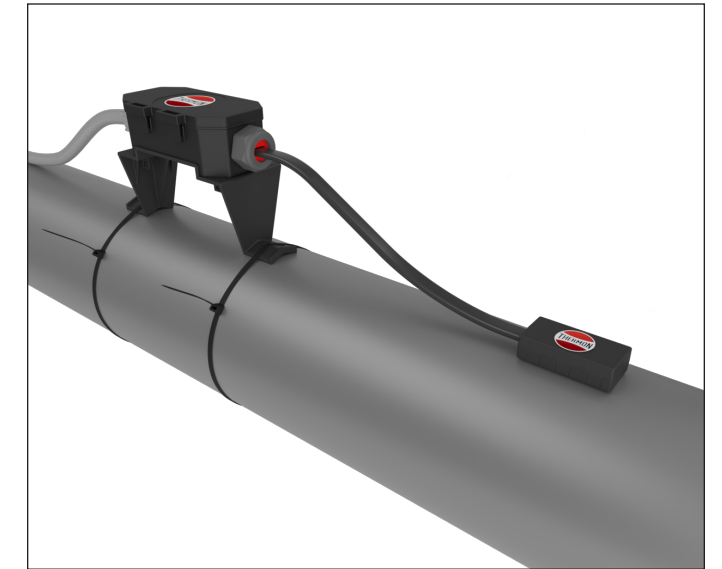

18. The heat trace circuit is now ready for taping to the piping, final electrical connections, and insulation.

TESTING & POWER CONNECTION

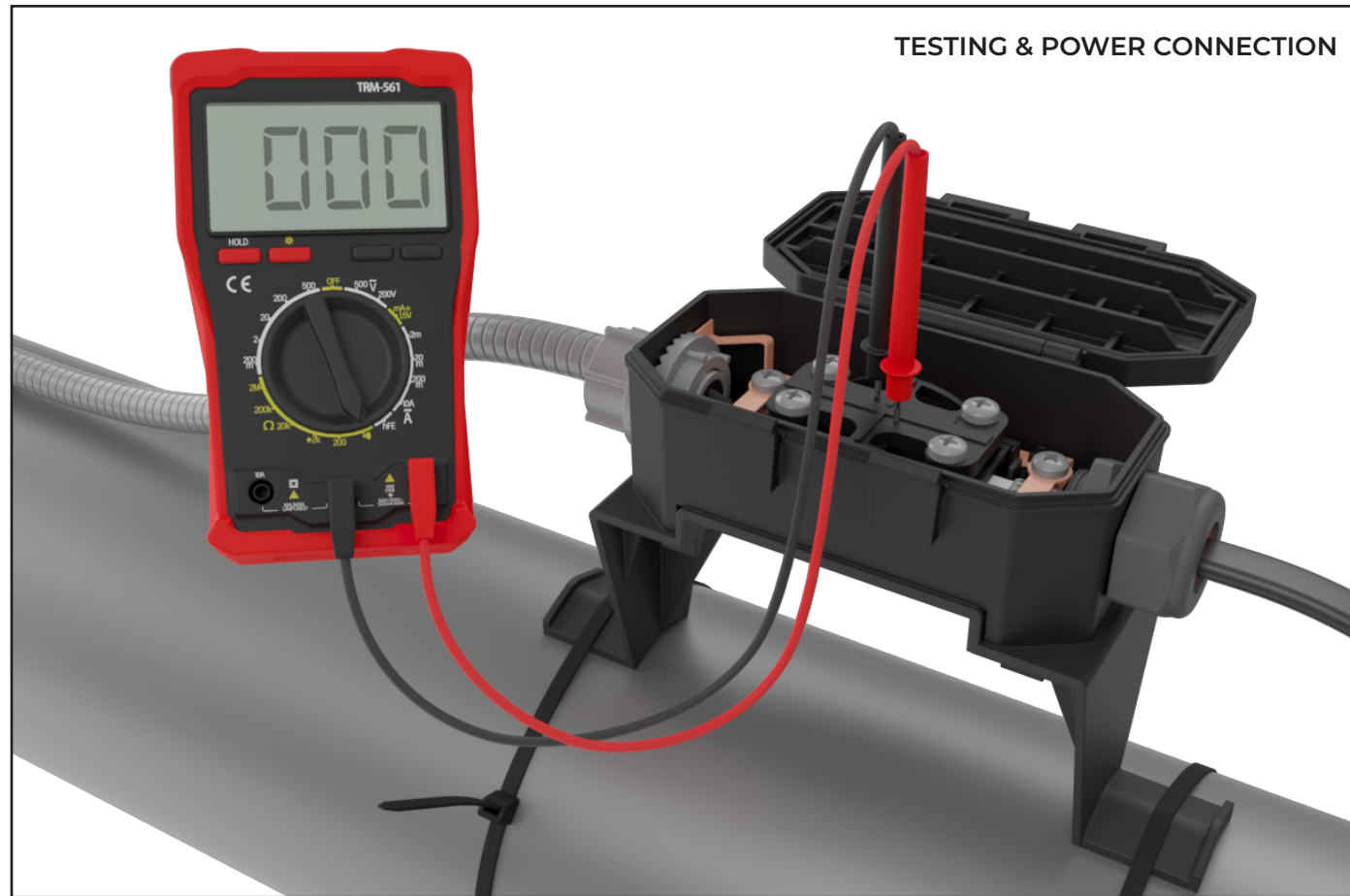

16. Test ports are included in all **LINK** IDC models to help the heat trace installer confirm there is continuity across the device after the connection is made. Please refer to the heat trace design guide and installation instructions for detailed information about heat trace use. Please refer to the instruction manual of the specific multimeter being used as exact details will vary by model. The basic process for continuity testing is as follows:

1. **WARNING:** Ensure power source is not energized.
2. Set multimeter to the Continuity Test function.
3. Place a multimeter probe in each test port.
4. Confirm continuity on multimeter (refer to multimeter manual for exact reading and form of continuity indication).

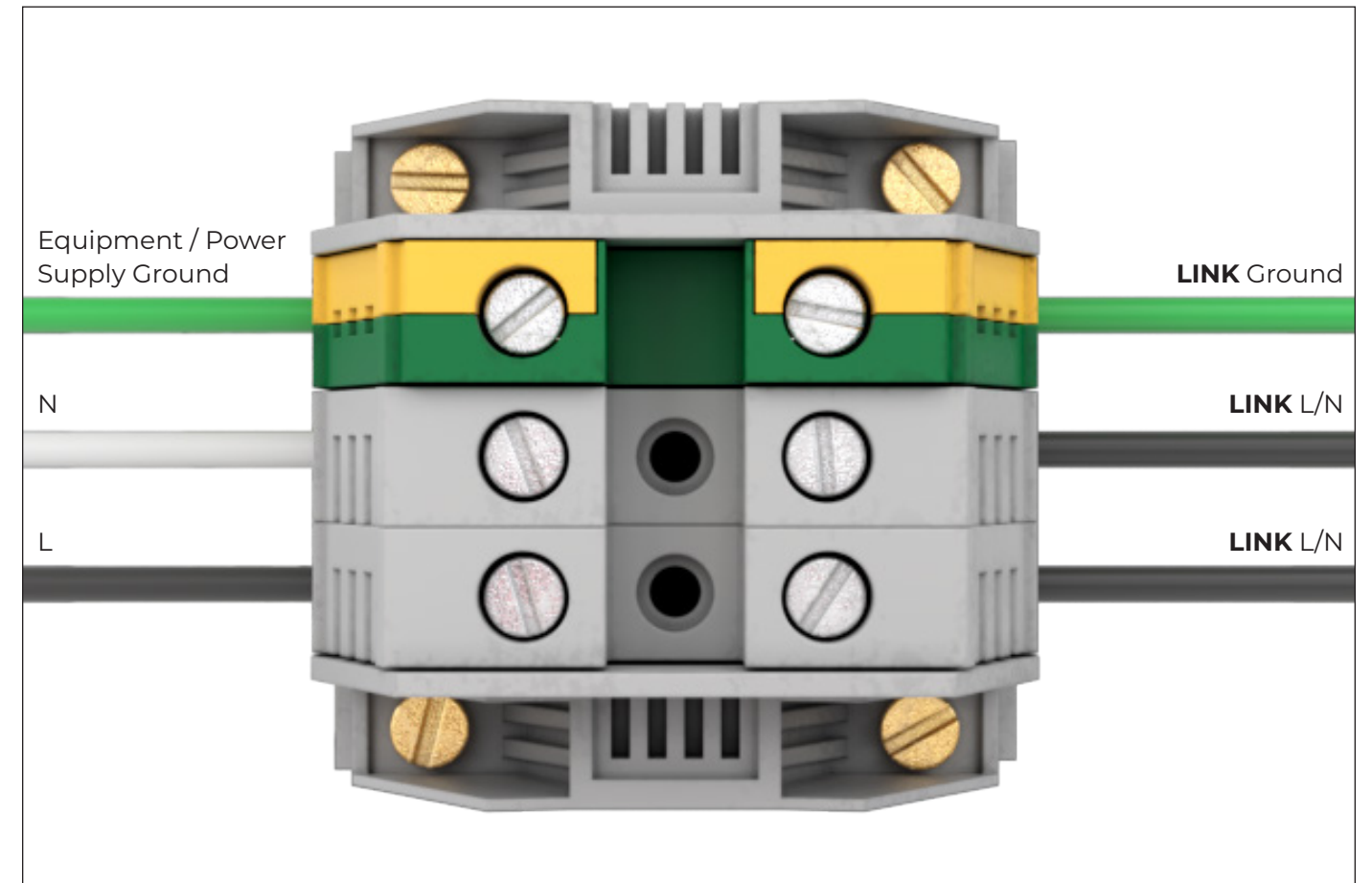

19. Complete system wiring according to customer design. Customer supplied terminal blocks, lugs, wire nuts, or other suitable and appropriately rated connection equipment to be used. Refer to typical terminal block example shown above.

THERMON LINK™

a degree above | www.thermon.com



CORPORATE HEADQUARTERS:

7171 Southwest Parkway · Building 300, Suite 200 ·
Austin, TX 78735 · Phone: 512-690-0600

For the Thermon office nearest you, visit us at www.thermon.com.
© Thermon, Inc. · Printed in U.S.A. · Information subject to change.