

Terminator DP/FAK-2 and FAK-2L

Elbow Splice Kit for
Electrically Heated
TubeTrace® Bundles

INSTALLATION PROCEDURES



Terminator DP/FAK-2 and FAK-2L

The following installation procedures are suggested guidelines for the installation of the Terminator DP/FAK-2 and FAK-2L Kit.

Receiving, Storing and Handling

1. Inspect materials for damage incurred during shipping.
2. Report damages to the carrier for settlement.
3. Identify parts against the packing list to ensure the proper type and quantity has been received.
4. Store in a dry location.

Terminator DP/FAK-2 and 2L Kit Contents



Item	Quantity	Description
1	1	Expediter Assembly: Flat Mount Base, Grommet, Threaded Grommet Compressor, and Support Cap with O-Ring
2	1	Junction Box Lid
3	1	Junction Box Base with O-Ring
4	1	Nut
5	1	Terminal Blocks with DIN Rail (Refer to terminal specifications for maximum allowable wire size)
6	1	Junction Box Cord
7	1	90° Elbow Splice Cover (Top)
8	1	90° Elbow Splice Cover (Bottom)
9	1	Heat Reflective Tape
10	2 (FAK-2) 3 (FAK-2L)	RTV Sealant Tube
11	1	Glass Fiber Tape
12	1	Silicone Gasket
13	1	Self-Vulcanizing Tape

Dimensions

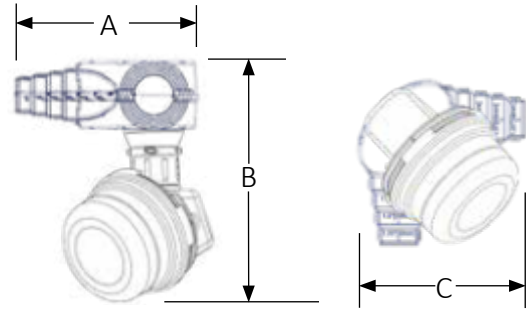

	A mm (inch)	B mm (inch)	C mm (inch)
Terminator DP/ FAK-2	187 mm (7-3/8")	277 mm (11-7/8")	187 mm (7-3/8")
Terminator DP/ FAK-2L	328 mm (12-7/8")	321 mm (12-5/8")	328 mm (12-7/8")

Required: Order Separately for each heater to be fabricated

PETK Power and End Termination Kits (per heater)

- PETK-1D for BSX, RSX, VSX-HT
- PETK-2D for KSX, HTSX
- PETK-3D for FP, HPT

Tools Required



INSTALLATION PROCEDURES

The Terminator DP/FAK-2 and FAK-2L In-Line Splice Kit is designed to make a waterproof seal over the end of TubeTrace at the splice connections. Review instructions prior to installation. Kit will make one splice connection (tube fittings not included). See separate instructions for details on splicing heat tracing.

Terminator DP Certifications/Approvals



IP66 NEMA/Type 4X $-60^{\circ}\text{C} \leq T_a \leq +55^{\circ}\text{C}$
 Ordinary & Hazardous Locations
 Class I, Division 2, Groups A, B, C, & D, Zone 2 IIC
 Class II, Division 2, Groups F & G, Class III
 Listed Heat Tracing System 137M



Installation Precautions

- To minimize the potential for arcing and ground-fault protection. The National Electrical Code (NEC) and Canadian Electrical Code (CEC) require ground-fault protection of equipment for each branch circuit supplying electric heat tracing.
- Installation must comply with Thermon requirements and be installed in accordance with the NEC, CEC, or any other applicable national and local codes.
- Component approvals and performance ratings are based on the use of Thermon specified parts only. User supplied power connection fittings must be listed or certified for intended use.
- De-energize all power sources before opening enclosure.
- Keep ends of heating cable and kit components dry before and during installation.
- Individuals installing these products are responsible for complying with all applicable safety and health guidelines. Proper personal protective equipment, or PPE, should be utilized during installation. Contact Thermon if you have any additional questions.

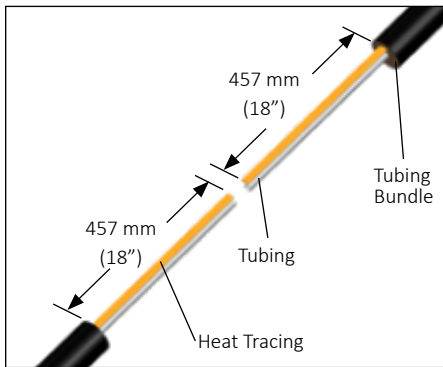

1. Remove outer jacket and insulation from tubing bundle approximately 457 mm (18") from end of the tubing bundle.



Do not cut or damage the heat trace or sampling tube.

CAUTION (Found on TubeTrace SE/ME bundles)

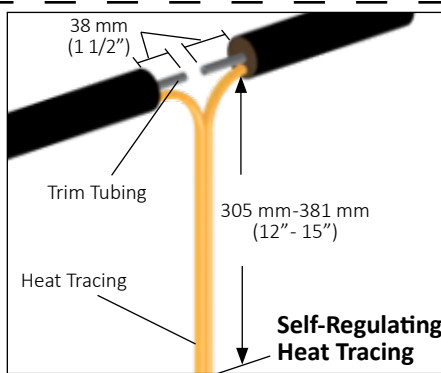

2. Trim tubing to within 38 mm (1-1/2") of the end of the insulation. If self regulating heat trace proceed to step 3. For Zone-type heat trace continue with identification of bus connection on step 2a.

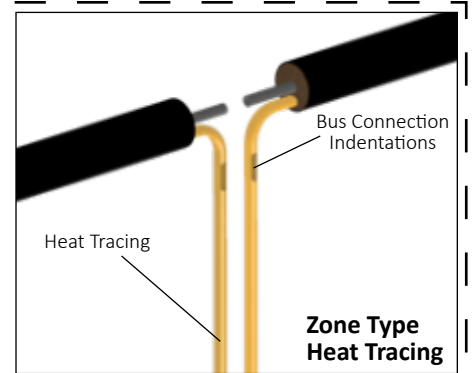

- 2a. Strip back bundle insulation 38 mm (1 1/2") to 76 mm (3") beyond bus connection indentation of each heat trace. If bus connection indentation is less than 305 mm (12")- 381 mm (15") from end of the heat tracing, proceed stripping the bundle insulation to the next indentation.

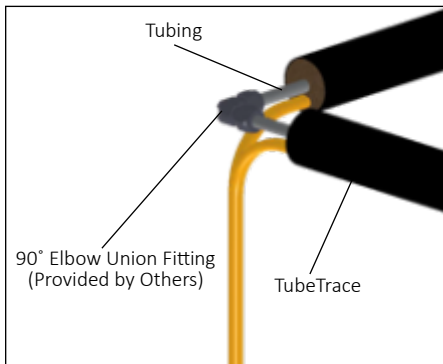

3. Make 90° elbow union connections (fitting provided by others). Test fitting for leaks before proceeding.

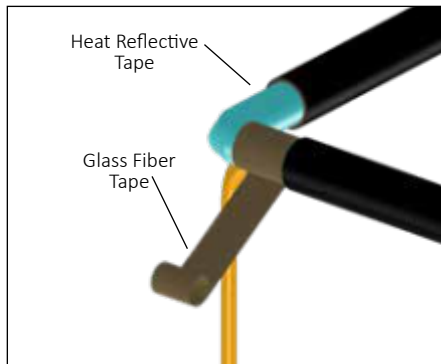

4. Wrap tube and heat trace with 1 pass of reflective tape (25% overlap), then wrap with 3 passes of glass fiber tape (50% overlap), or until fiber tape is equal to original bundle insulation thickness.

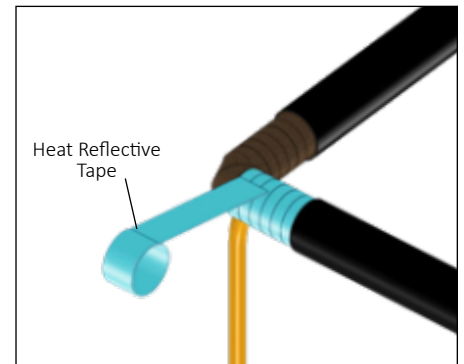

5. Complete with additional passes of heat reflective tape.

Terminator DP/FAK-2 and FAK-2L

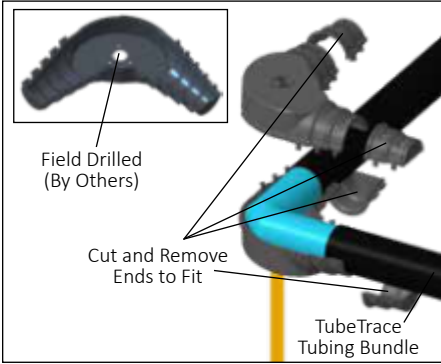

6. Cut splice cover top and splice cover bottom to match outside diameter of tubing bundle.

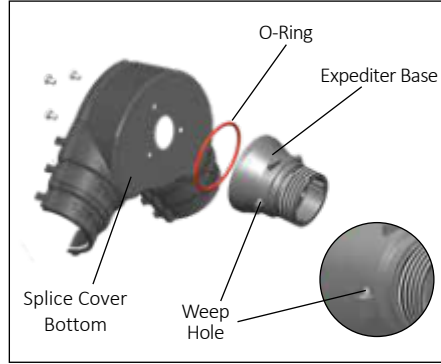

7. Mount expediter base with o-ring to splice cover bottom using (3) M5 mounting screws and lock washers. Punch out weep hole.

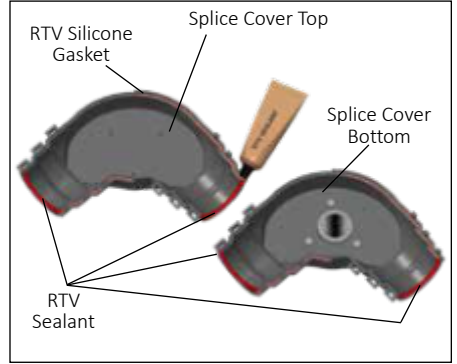

8. Install the Silicone Gasket (cut off excess). Apply RTV Sealant to both halves.

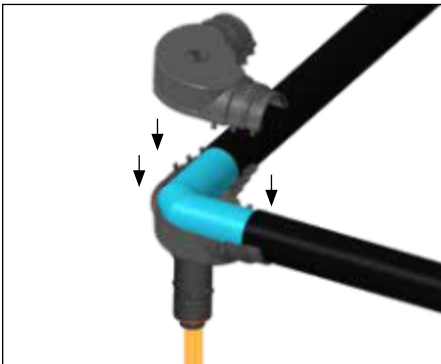

9. Assemble splice cover top, tubing bundle, and splice cover bottom together as shown. Snap together firmly. Inspect ends of tubing splice cover for snug fit. Apply additional RTV sealant where needed.



10. Apply self-vulcanizing tape around bundle jacket and work up over FAK ends.

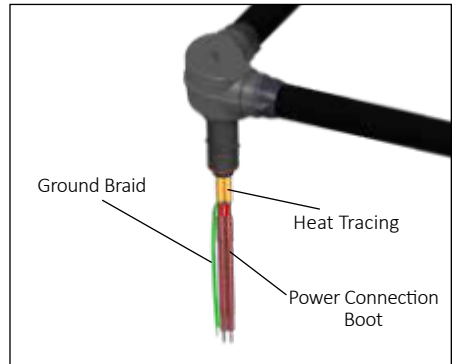

11. Terminate heat tracing with appropriate PETK termination kit. Refer to PETK installation instructions (purchased separately) for details not addressed here.

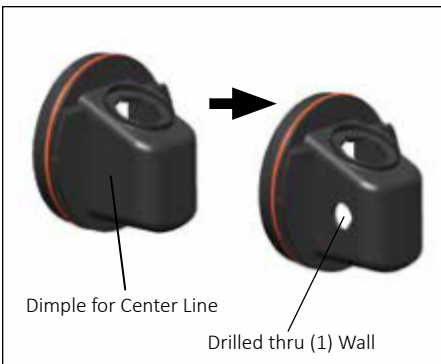

12. For power connection applications: Use dimple molded into side of junction box base to locate center hole, drill for user supplied power connection fitting per manufacturer's recommendations.



13. Mount junction box on expediter making sure to align slots to properly orient junction box base.

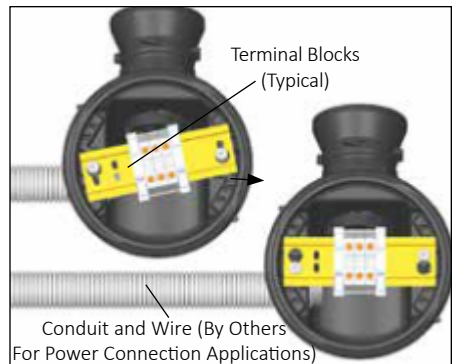

14. Install quick mount terminal blocks twist to position and tighten screws.

INSTALLATION PROCEDURES

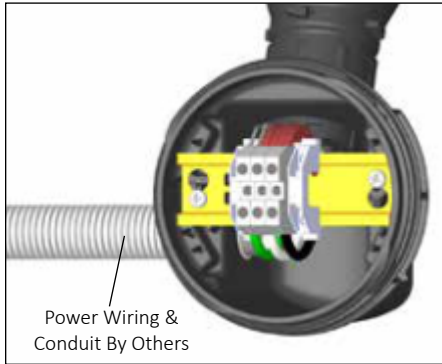

15. Complete system wiring between fabricated heat tracing and power supply wiring. See wiring diagram.

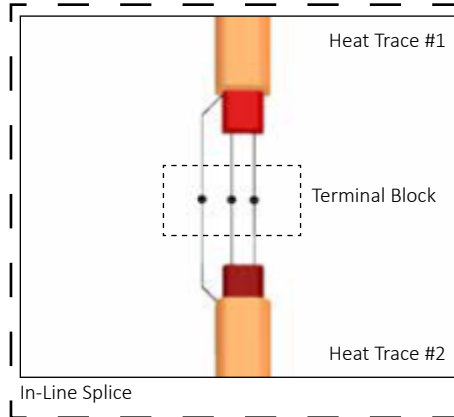

In-Line Splice

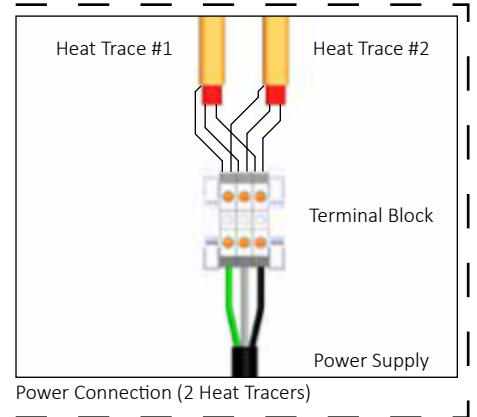

Power Connection (2 Heat Tracers)



16. Install junction box lid and twist hand tight. Insert screwdriver into ratchet slot located on side of junction box base to tighten. Use screwdriver ratchet on junction box lid. Lid will rotate 30°.



17. Lid latch mechanism fully engaged. To remove lid, repeat step 15 but in opposite direction.



18. Completed Terminator DP/FAK-2/2L power assembly for Electrically Heated TubeTrace Bundles. (Installation shown is to feed power in the middle of a TubeTrace bundle. Many installations will be near the end of a TubeTrace bundle.)

