

FAK-2LHT

Elbow Splice Kit for
Tubing Bundles

INSTALLATION PROCEDURES



FAK-2LHT Elbow Splice Kit

The FAK 2LHT Elbow Splice Kit is designed to make a waterproof seal over the end of Fluid/Steam Heated TubeTrace or ThermoTube where a 90° elbow is required. Review instructions prior to installation. Kit will make one splice connection.

Receiving, Storing and Handling

1. Inspect materials for damage incurred during shipping.
2. Report damages to the carrier for settlement.
3. Identify parts against the packing list to ensure the proper type and quantity has been received.
4. Store in a dry location.

FAK-2LHT Elbow Splice Kit

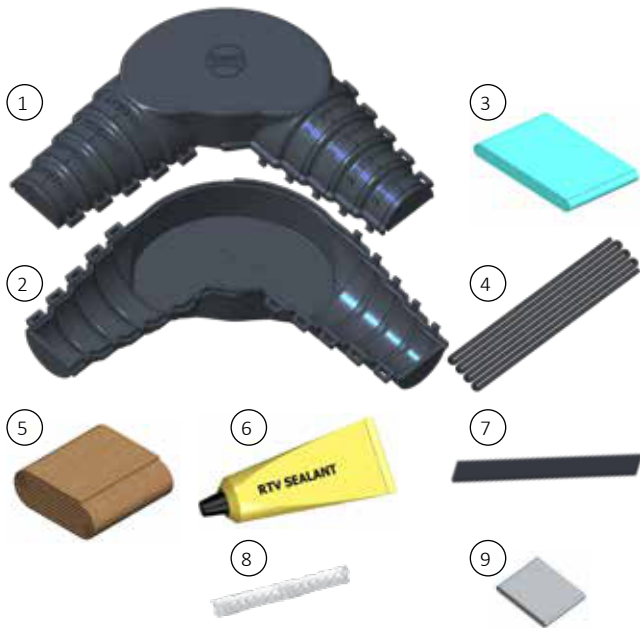

Item	Quantity	Description
1	1	90° Elbow Splice Cover (Top)
2	1	90° Elbow Splice Cover (Bottom)
3	1	Heat Reflective Tape
4	1	Silicone Gasket
5	1	Glass Fiber Tape
6	3	RTV Sealant Tube
7	1	Self-Vulcanizing Tape
8	1	Fiberglass Rope, 13 mm x 366 cm (1/2"x 12')
9	1	Heavy Foil Tape, 44.5 mm (1.75") wide

Dimensions

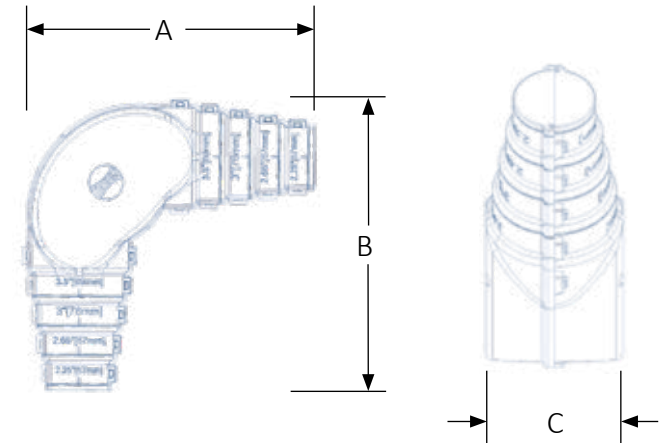

	A mm (inch)	B mm (inch)	C mm (inch)
FAK-2LHT	328 mm (12-7/8")	328 mm (12-7/8")	111 mm (4-3/8")

Installation Precautions

- Installation must comply with Thermon requirements and be installed in accordance with the any other applicable local codes.
- Warranty and performance ratings are based on the use of Thermon specified parts only.
- Individuals installing these products are responsible for complying with all applicable safety and health guidelines. Proper personal protective equipment, or PPE, should be utilized during installation. Contact Thermon if you have any additional questions.

Tools Required



INSTALLATION PROCEDURES

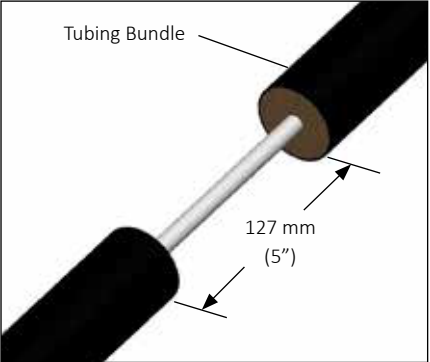

1. Remove approximately 127 mm (1/2") of outer jacket and insulation from tubing bundle.

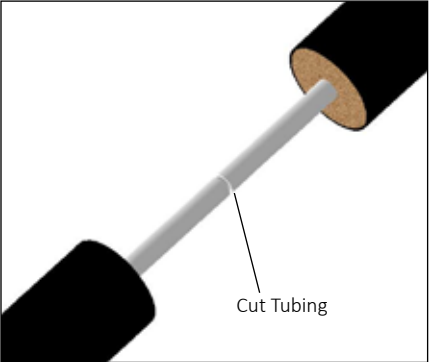

2. Cut tubing insuring a clean, square cut. De-burr tube ends.

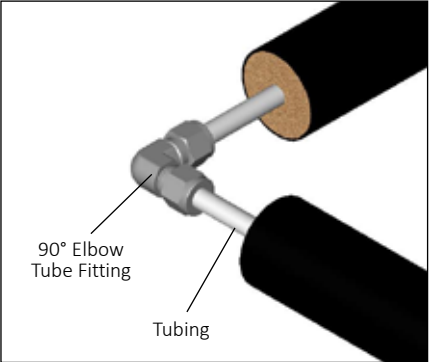

3. Make 90° elbow tube fitting connections. Tube fitting(s) provided by others.

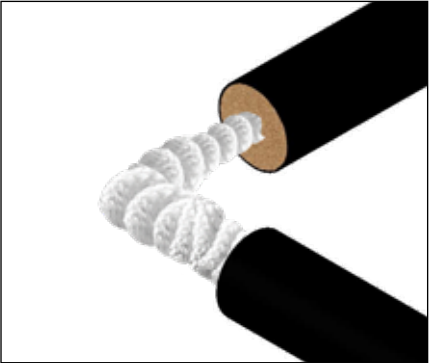

4. Wrap high temperature tubing with 127 mm (1/2") fiberglass rope. Ensure 100% coverage.

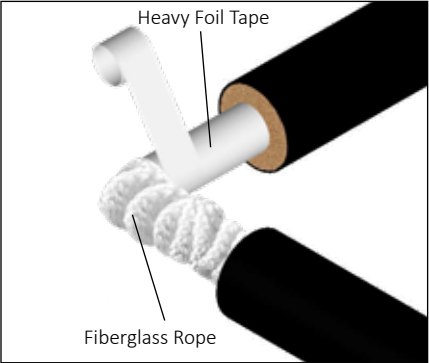

5. Wrap rope with one pass of heavy foil tape (25% overlap).

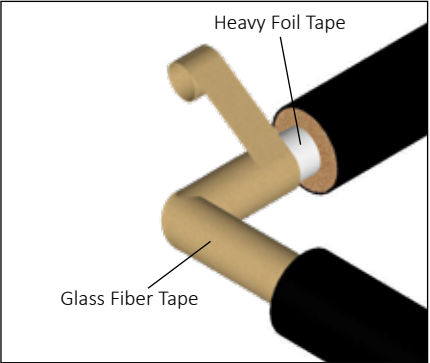

6. Wrap with 3 passes of glass fiber tape (50% overlap).

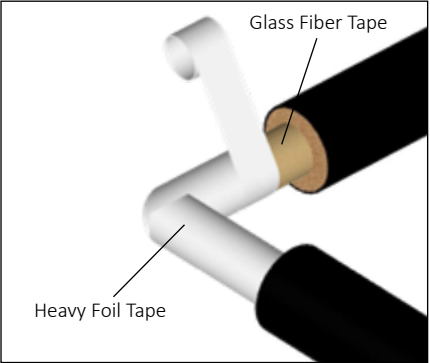

7. Add 1 additional pass of heavy foil tape (25% overlap).

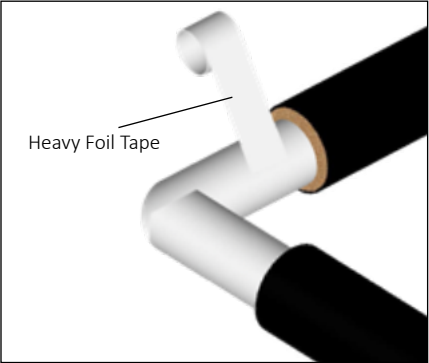

8. Complete with 1 additional pass of heavy foil tape (25% overlap) to cover heat trace.

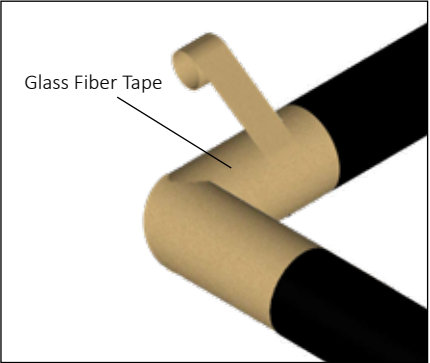

9. Wrap with 4 passes of glass fiber tape (50% overlap), or until fibertape is equal to original bundle insulation thickness.

FAK-2LHT Elbow Splice Kit

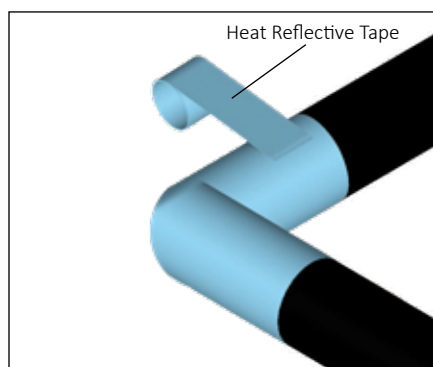

10. Wrap with 1 additional pass of heat reflective tape (50% overlap).

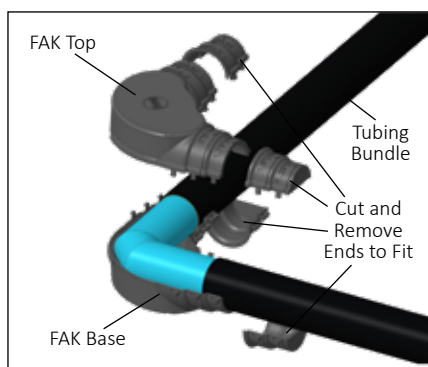

11. Using the dimensions on the splice covers, locate the correct size, ensuring a snug fit. Identify the correct cut line and cut top and bottom of splice connectors.

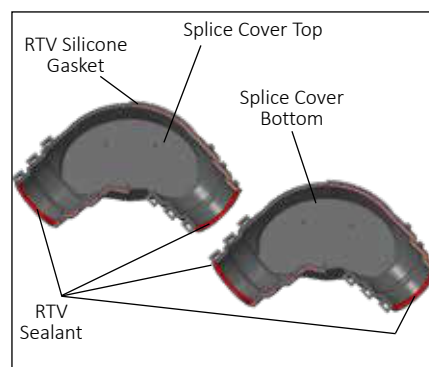

12. Install the Silicone Gasket (cut off excess). Apply RTV Sealant to both halves.

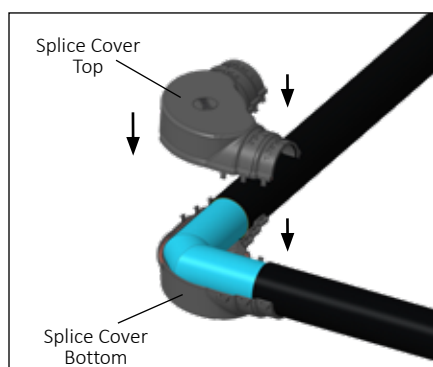

13. Fit tubing bundle to bottom half of cover and install top half. Snap both halves together firmly. Inspect ends of tubing splice cover for snug fit. Apply additional RTV sealant where needed.



14. Apply Self-Vulcanizing Tape around bundle jacket and work up over FAK ends.



15. Completed FAK-2LHT kit.

