

Terminator ZP/FAK-1

For Bulkhead Entry of
Electrically Heated
TubeTrace® Bundles

INSTALLATION PROCEDURES



Terminator ZP/FAK-1

The following installation procedures are suggested guidelines for the installation of the Terminator ZP/FAK-1 Bulkhead Entry Kit.

Receiving, Storing and Handling

1. Inspect materials for damage incurred during shipping.
2. Report damages to the carrier for settlement.
3. Identify parts against the packing list to ensure the proper type and quantity has been received.
4. Store in a dry location.

Terminator ZP/FAK-1 Kit Contents



Item	Quantity	Description
1	1	Expediter Assembly: Flat Mount Base, Grommet, Threaded Grommet Compressor, and Support Cap with O-Ring
2	1	Junction Box Lid
3	1	Junction Box Base with O-Ring
4	1	Nut
5	1	Terminal Blocks with DIN Rail (Refer to terminal specifications for maximum allowable wire size)
6	1	Junction Box Cord
7	1	FAK-1 Cover (Top)
8	1	FAK-1 Cover (Bottom)
9	1	Heat Reflective Tape
10	2	RTV Sealant Tube
11	1	Glass Fiber Tape
12	1	Silicone Gasket
13	1	Self-Vulcanizing Tape

Provided by others — 8 each 8-32 stainless steel bolts, washers and nuts required.

Dimensions

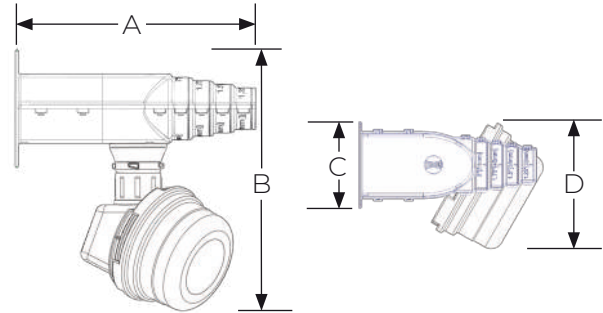

	A	B	C	D
	mm (inch)	mm (inch)	mm (inch)	mm (inch)
Terminator ZP/FAK-1	220 mm (8-5/8")	277 mm (11-7/8")	107 mm (4-1/4")	171 mm (6-3/4")

Required: Order Separately for each heater to be fabricated

PETK Power and End Termination Kits (per heater)

- PETK-1 for BSX, RSX, VSX-HT
- PETK-2 for KSX, HTSX
- PETK-3 for FP, HPT

Tools Required



Terminator ZP Certifications/Approvals



European Organisation for Electrotechnical Standardisation
Hazardous (Classified) Locations



II 2 GD Ex eb IIC T4-T6, Ex tb IIIC T135°C-T85°C FM 10ATEX0058X



FMG 10.0022X Ex eb IIC T4-T6, Ex tb IIIC T135°C-T85°C



FM Approvals
Hazardous (Classified) Locations



Underwriters Laboratories Inc.
Hazardous (Classified) Locations

INSTALLATION PROCEDURES

The Terminator ZP/FAK-1 Split Bulkhead Entry Kit is designed to make a waterproof seal over the end of TubeTrace and terminate Thermon electric heat trace in an approved junction box. Review Instructions prior to installation. Kit will make one connection.

Installation Precautions

- To minimize the potential for arcing on electrical heat tracing and fire caused by product damage or improper installation, use ground-fault protection.
- Installation must comply with Thermon requirements and be installed in accordance with any applicable national and local codes.
- Component approvals and performance ratings are based on the use of Thermon specified parts only. User supplied power connection fittings must be listed or certified for intended use.
- De-energize all power sources before opening enclosure.
- Keep ends of bundles, heat tracing and kit components dry before and during installation.
- Individuals installing these products are responsible for complying with all applicable safety and health guidelines. Proper personal protective equipment, or PPE, should be utilized during installation. Contact Thermon if you have any additional questions.

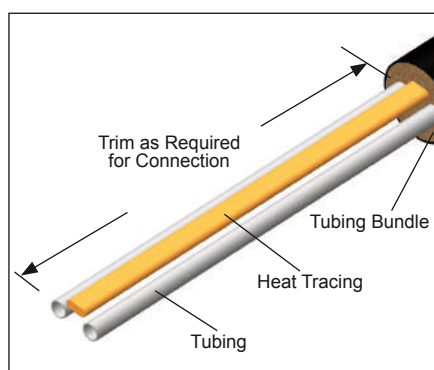

1. Remove outer jacket and insulation from tubing bundle as included from end of the tubing bundle. Ensure sufficient heat trace is available for electrical connection. See instructions included with heat trace PETK kit (purchased separately).



Do not cut or damage the heat trace or sampling tube.

CAUTION (Found on TubeTrace SE/ME bundles)

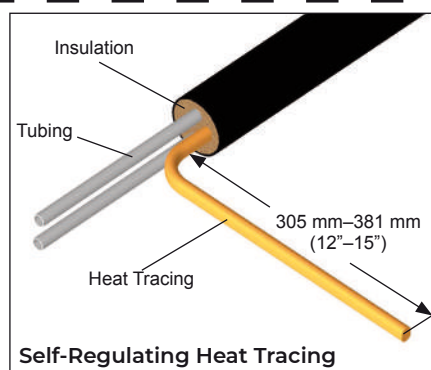

2. Trim heat tracing to within 305 mm–381 mm (12”–15”) of the end of the insulation. If self regulating heat trace proceed to step 3. For Zone-type heat trace continue with identification of bus connection on step 2a.

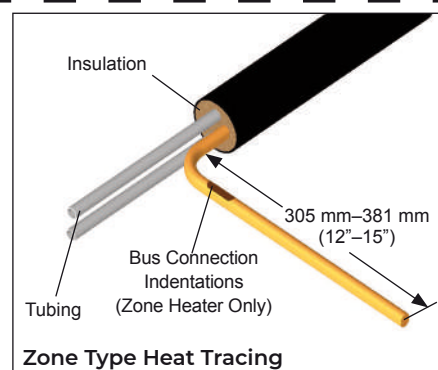

- 2a. Strip back bundle insulation 38 mm (1-1/2”) to 76 mm (3”) beyond bus connection heat tracing. If bus connection indentation is less than 305 mm–381 mm (12”–15”) from end of the heat tracing, proceed stripping the bundle insulation to the next indentation.

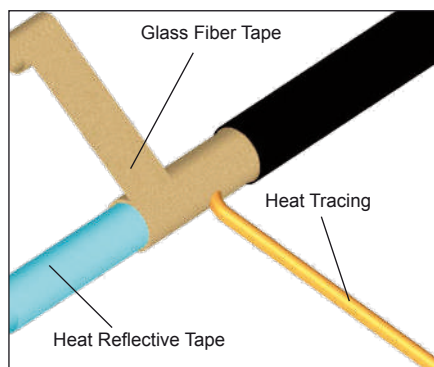

3. Wrap tubes and heat tracing with pass of heat reflective tape (25% overlap). Then wrap with 3 passes of glass fiber tape (50% overlap), or until fiber tape is equal to original bundle insulation thickness.

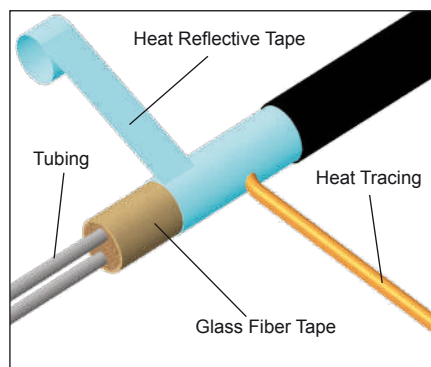

4. Complete with additional passes of heat reflective tape.

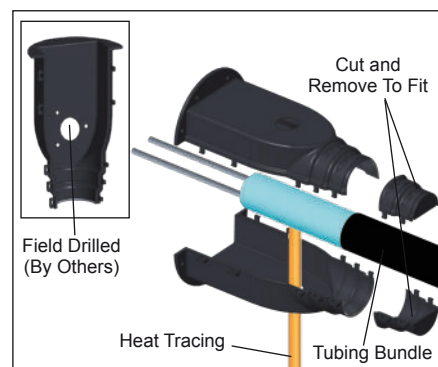

5. Cut FAK-1 top and base ends to match outside diameter of tubing bundle and remove end pieces.

Terminator ZP/FAK-1

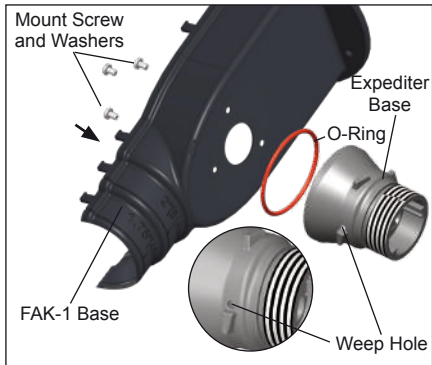

6. Mount expediter base with o-ring to FAK-1 base using (3) M5 mounting screws and lock washers. Punch out weep hole.

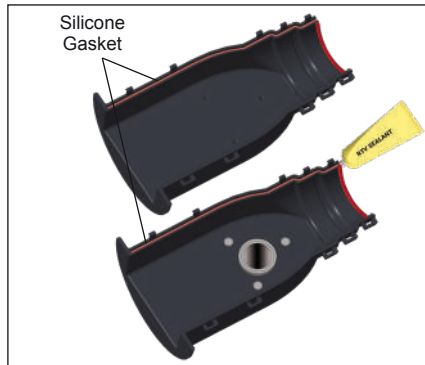

7. Install RTV silicone and gasket, cutting off excess. Apply RTV sealant to both halves.

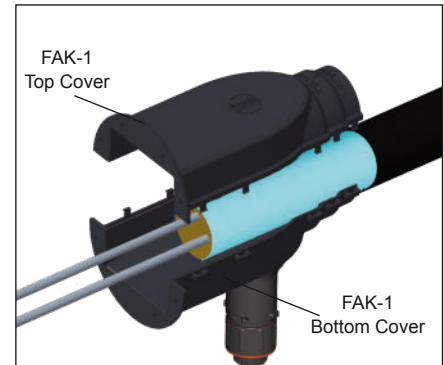

8. Assemble FAK-1 top, tubing bundle, and FAK-1 bottom together as shown. Snap together firmly. Inspect ends of tubing splice cover for snug fit. Apply additional RTV sealant where needed.



9. Apply self-vulcanizing tape around bundle jacket and work up over FAK-1 ends.

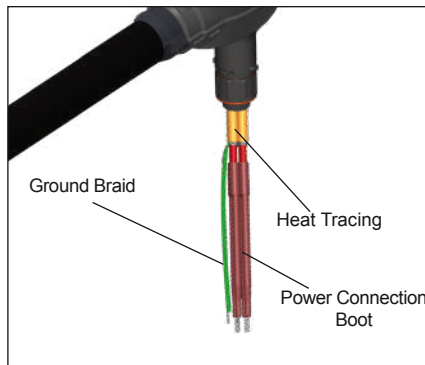

10. Terminate heat tracing with appropriate PETK termination kit. Refer to PETK installation instructions (purchase separately) for details not addressed here.

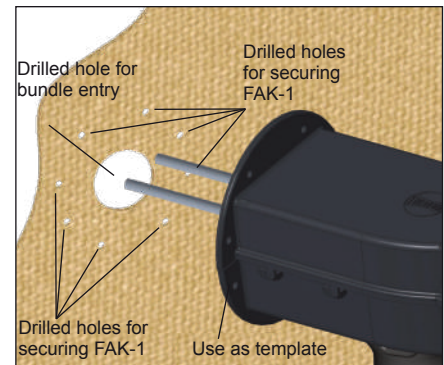

11. Field drill required entry hole in wall/plate. Use the FAK-1 flange as a template and mark and drill holes for bolts.

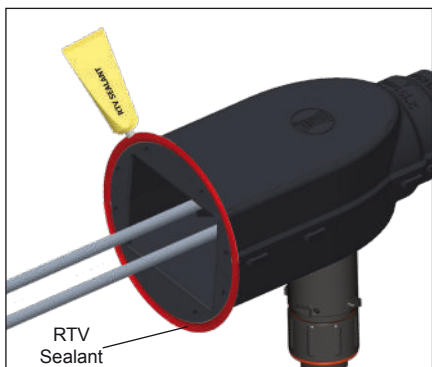

12. Apply RTV bead to back of FAK-1 flange prior to securing to bulkhead.

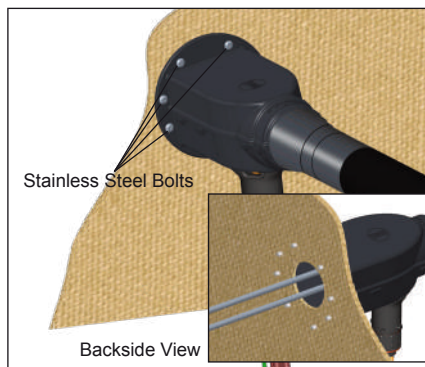

13. Secure FAK-1 to bulkhead/wall using (8) eight stainless steel bolts. Note: stainless steel bolts, washers, and nuts provided by others. Recommended bolt size is 8-32.



14. Apply RTV bead around FAK-1 flange.

INSTALLATION PROCEDURES

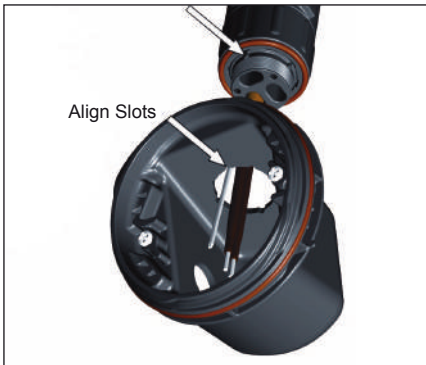

15. Mount junction box on expediter making sure to align slots to properly orient junction box base.

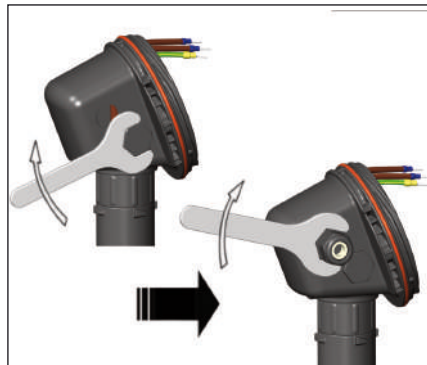

16. Remove M25 dust cap. Install M25 power gland (order separately) and M25 blind plug. For in-line splice, T-splice, or end termination, install additional M25 blind plug (order M25-B-EXE separately) instead of M25 power gland.

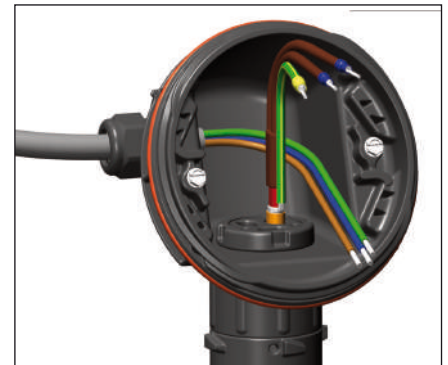

17. Install power cable.

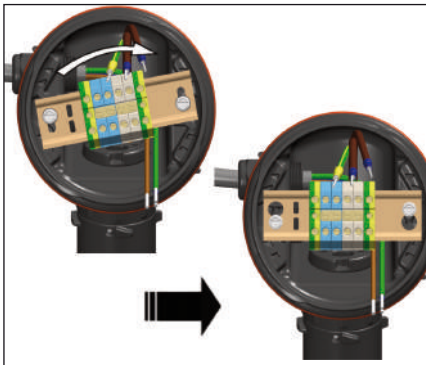

18. Install terminal block and complete system wiring. Terminal set screws shall be tightened to a torque value of 1.4 Nm (12.4 lb-in). See below for wiring details.



19. Install junction box lid and twist hand tight. Insert screwdriver into ratchet slot located on side of junction box base to tighten. Use screwdriver ratchet on junction box lid. Lid will rotate 30°.

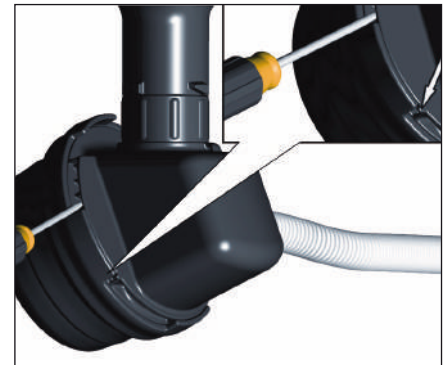

20. Lid latch mechanism fully engaged. To remove lid, repeat step 19 but in opposite direction.

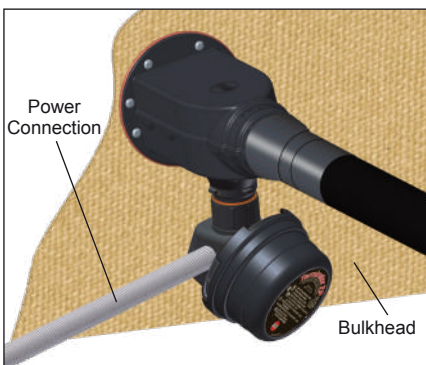

21. Completed Terminator ZP/FAK-1 for bulkhead entry of electrically heated TubeTrace bundles.

Wiring Details

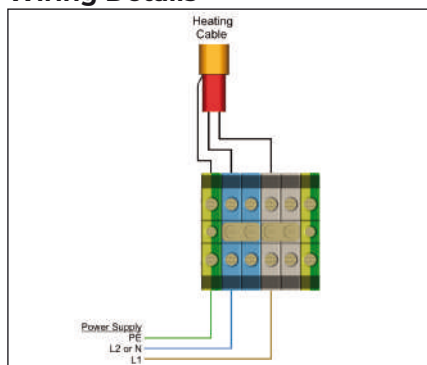

Power Connection (1 to 3 Heating Cables)

