

Terminator™ ZT-MI-WP
Terminator™ ZT-C-MI-WP
Thermostat Connection Kit
INSTALLATION PROCEDURES



**For Thermostat Connection (1-2 Heating Cables) Applications
For Use With MI Mineral Insulated Heating Cable Sets**



Terminator™ ZT-(C)-MI-WP INSTALLATION PROCEDURES

The following installation procedures are guidelines for the installation of the Terminator ZT-MI-WP & ZT-C-MI-WP Kits.

Receiving, Storing and Handling . . .

1. Inspect materials for damage incurred during shipping.
2. Report damages to the carrier for settlement.
3. Identify parts against the packing list to ensure the proper type and quantity has been received.
4. Store in a dry location.

Kit Contents . . .



Item	Quantity	Description						
1	1	Expediter Assembly Support Cap with O-Ring Threaded Grommet Compressor Grommet Support Base with O-Ring						
2	1	Junction Box Lid						
3	1	Junction Box Base with O-Ring & M25 Dust Cap						
4	1	Nut						
5	1	Banding						
6	1	Thermostat w/ Terminal Blocks (Refer to terminal specifications for maximum allowable wire size)						
		<table border="0"> <tr> <td><u>Thermostat Type</u></td> <td><u>Terminals</u></td> </tr> <tr> <td>ZT-C-230 Vac</td> <td>4 mm² terminals</td> </tr> <tr> <td>ZT-C-400 Vac</td> <td>6 mm² terminals</td> </tr> </table>	<u>Thermostat Type</u>	<u>Terminals</u>	ZT-C-230 Vac	4 mm ² terminals	ZT-C-400 Vac	6 mm ² terminals
<u>Thermostat Type</u>	<u>Terminals</u>							
ZT-C-230 Vac	4 mm ² terminals							
ZT-C-400 Vac	6 mm ² terminals							
7	1	Capillary Armoring w/ Glands						
8	1	Junction Box Cord						
9	2	Blind Plug M20						
10	1	Bracket						
11	3	Screws						
12	3	Washers						
13	1	Earthtag with Earthwire						
14	1	Locknut Brass						
15	1	Blind Plug M25						

Dimensions . . .

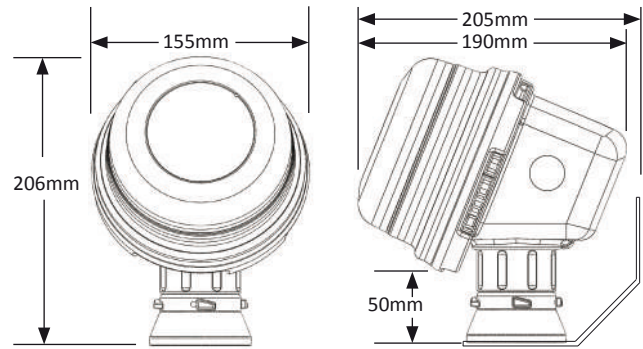

Warnings

- Due to the risk of electrical shock, arcing and fire caused by product damage or improper usage, installation or maintenance, a ground-fault protection device is required.
- Installation must comply with Thermon requirements (including form PN 50273U for Ex systems) and be installed in accordance with the regulations as per the norm EN IEC 60079-14 for hazardous areas (where applicable), or any other applicable national and local codes.
- Component approvals and performance ratings are based on the use of Thermon specified parts only.
- De-energize all power sources before opening enclosure.
- Avoid electrostatic charge. Clean only with a damp cloth.
- Keep ends of heating cable and kit components dry before and during installation.
- Minimum bending radius of heating cable is 6 times the cable outer diameter.
- Individuals installing these products are responsible for complying with all applicable safety and health guidelines. Proper Personal Protective Equipment (PPE) should be utilized during installation. Contact TC-E if you have any additional questions.

Tools Required



Certifications/Approvals

IP66; -60°C ≤ Ta ≤ +55°C T6, 85°C 16 Amps Max
-60°C ≤ Ta ≤ +50°C T5, 100°C 25 Amps Max
Ordinary & Hazardous Locations

Terminator ZT

FMG 10.0022X Ex db eb IIC T5-T6, Ex tb IIIC T100°C-T85°C

2809 Ex II 2 GD Ex db eb IIC T5-T6, Ex tb IIIC T100°C-T85°C FM10ATEX0058X

Terminator ZT-C

EPS 19.0094X Ex db eb IIC T5-T6, Ex tb IIIC T100°C-T85°C

2809 Ex II 2 GD Ex db eb IIC T5-T6, Ex tb IIIC T100°C-T85°C EPS 19ATEX1216X

Terminator™ ZT-(C)-MI-WP INSTALLATION PROCEDURES

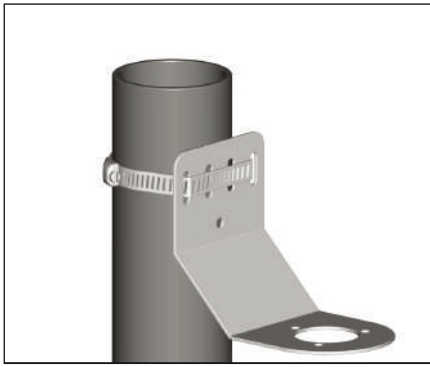

1a. Mounting Method 1: Secure wall mount bracket to mounting surface using pipe band provided with kits.

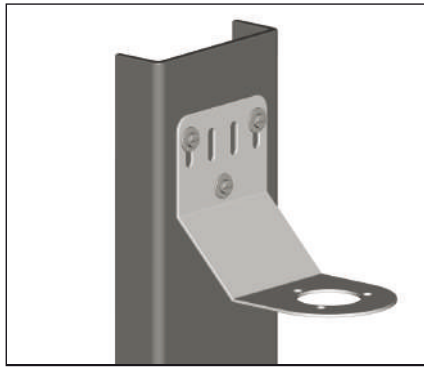

1b. Mounting Method 2: Secure wall mount bracket to mounting surface using customer supplied screws, flat washers, and nuts.

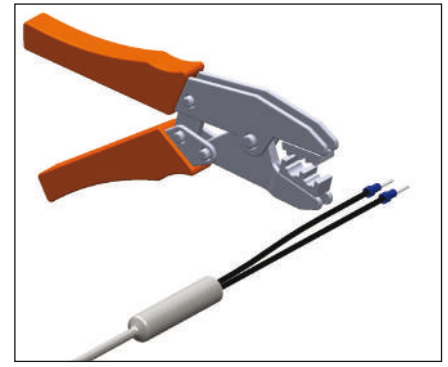

2. Crimp appropriate wire pins (2.5 mm² or 6 mm²) on MI cable cold lead wires.

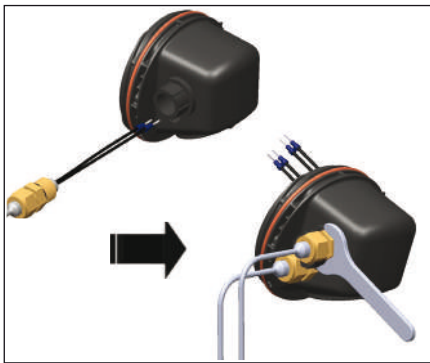

3. Route MI cable cold leads through M20 threaded entries. Screw cable glands into junction box.

CAUTION Do not overtighten to ensure o-ring is not damaged during installation.

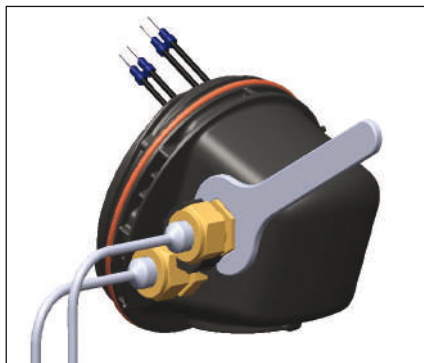

4. Center cold lead sleeve inside cable gland. Tighten cable glands until ferrule begins to make contact with cold lead sleeve and cold lead sleeve cannot be moved by hand. Tighten cable gland 1/8 additional turn or to a torque value of 16 Nm (142 lb-in).

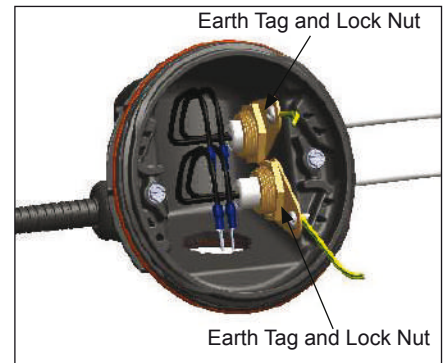

5. Install user supplied M20 Earth Tag and Lock Nut to threaded M20 Gland.

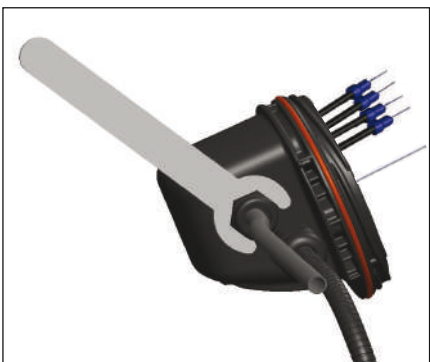

6. Remove M25 dust cap. Install M25 power gland (customer supplied) in M25 threaded entry.

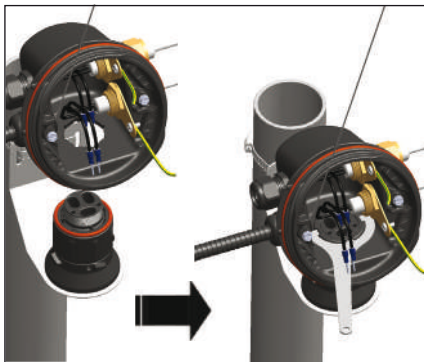

7. Mount junction box base on expediter. Make sure to align slots to properly orient junction box base. Tighten nut with Terminator-LN-Tool. If mounting horizontally, threaded gland holes must face downward.

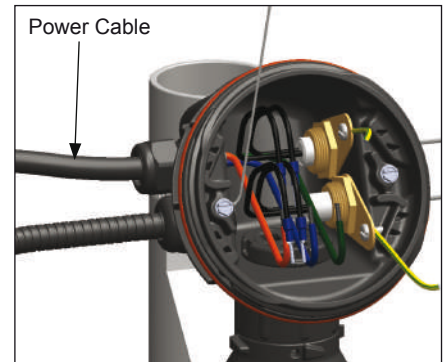

8. Install power cable (if necessary).

Terminator™ ZT-(C)-MI-WP INSTALLATION PROCEDURES

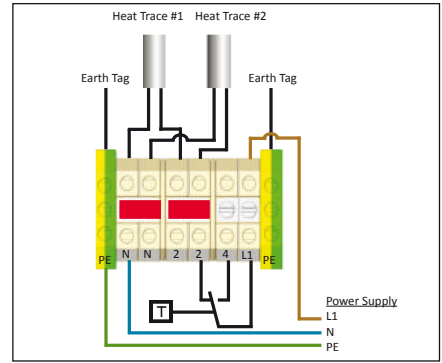
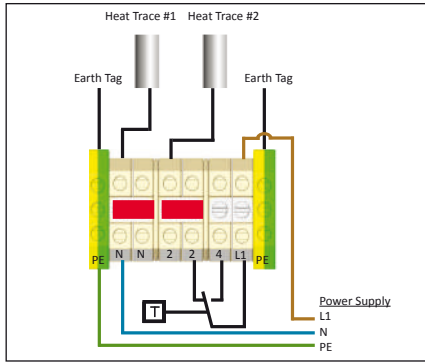
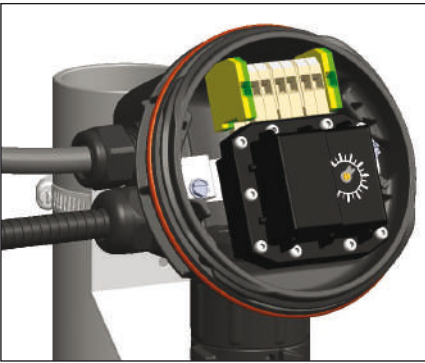

9. Install thermostat and complete system wiring. Terminal set screws shall be tightened to a torque value of 1.4 Nm (12.4 lb-in). See wiring diagrams for details. Set thermostat at desired setpoint.

Wiring Details: Single Core

Wiring Details: Dual Core



10. Install junction box lid and twist hand tight. Insert screwdriver into ratchet slots located on side of junction box base. Use screwdriver to ratchet on junction box lid. Lid will rotate 30 degrees. To remove lid, repeat steps in the opposite direction.

11. Fix thermostat bulb and capillary tube to pipe.

12. Seal penetration through insulation cladding.

