

MIQ™ Mineral Insulated Heating Cable

INSTALLATION PROCEDURES

(North America)

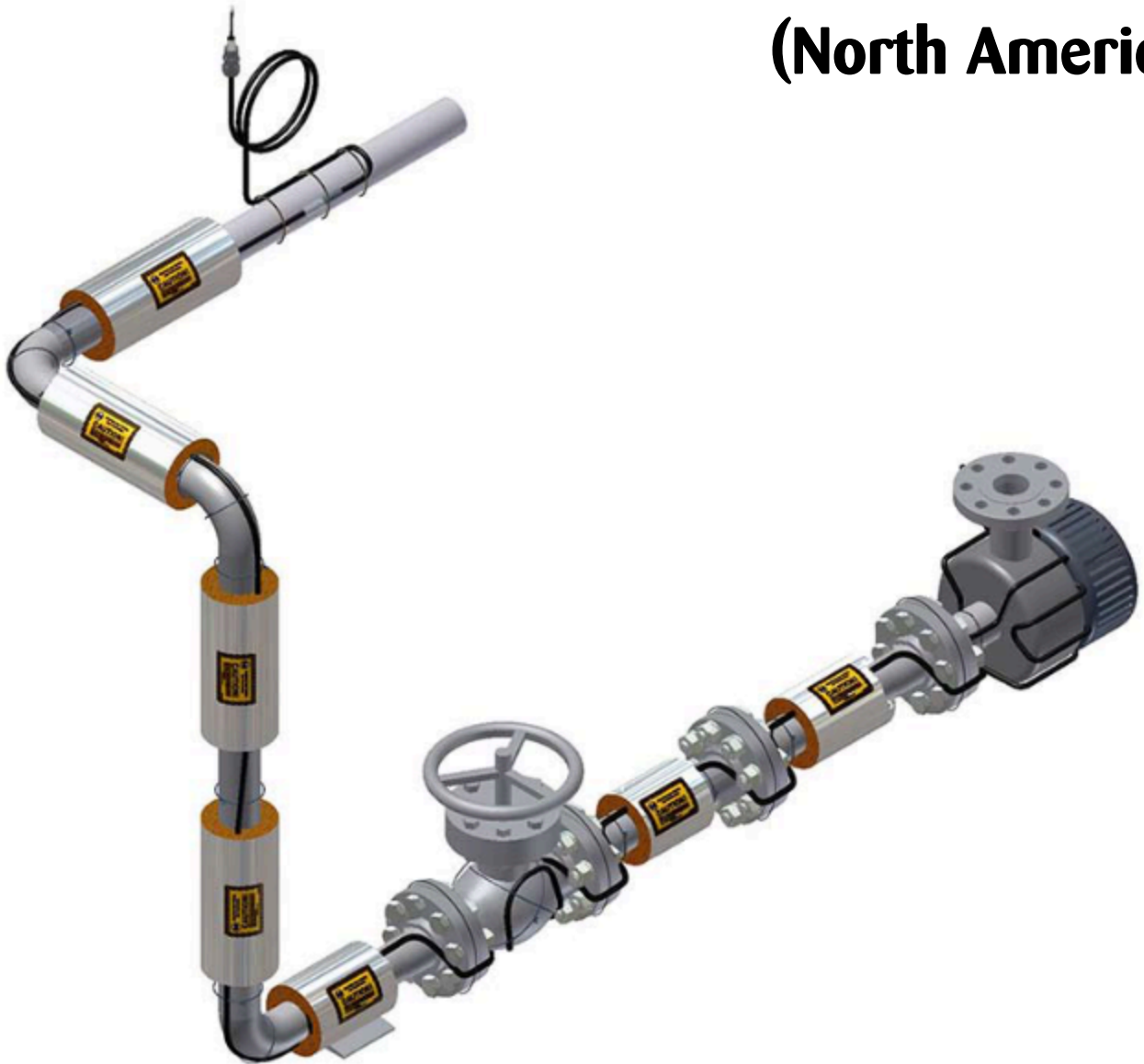

The Heat Tracing Specialists®

MIQ™ Mineral Insulated Heating Cable

The following installation procedures are suggested guidelines for the installation of a Thermon MIQ mineral insulated heat tracing system. Refer to project specifications, if applicable.

Applications . . .

1. MIQ heating cables are used for freeze protection or temperature maintenance of piping, tanks and instrumentation.
2. Heat tracing cables may be installed in ordinary (nonclassified) and hazardous (classified) locations depending on the specific cable options and approvals.



The National Electric Code and Canadian Electrical Code require ground-fault protection be provided for electric heat tracing.

Determine Heat loss. . .

There are several ways to determine the heat loss for pipes under given set of design conditions:

- Heat loss calculation such as those detailed in IEEE Std.515 (IEEE Standard for the Testing, Design, Installation, and Maintenance of Electrical Resistance Heat Tracing for Industrial Applications).
- Computer-aided design programs that allow the user to input detailed information specific to an application. (Thermon's CompuTrace® design and selection program provides this and more based on the formulas presented in IEEE Std.515).
- Heat loss charts based on selected pipe diameters, temperature differentials and insulation materials.
- Please contact TC-E for additional information on pipe and vessel heat loss.

MIQ Catalogue Reference Number . . .

A complete catalogue reference number will typically include the following components:

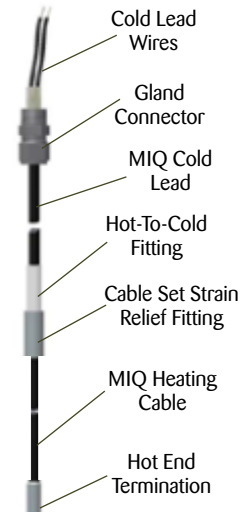
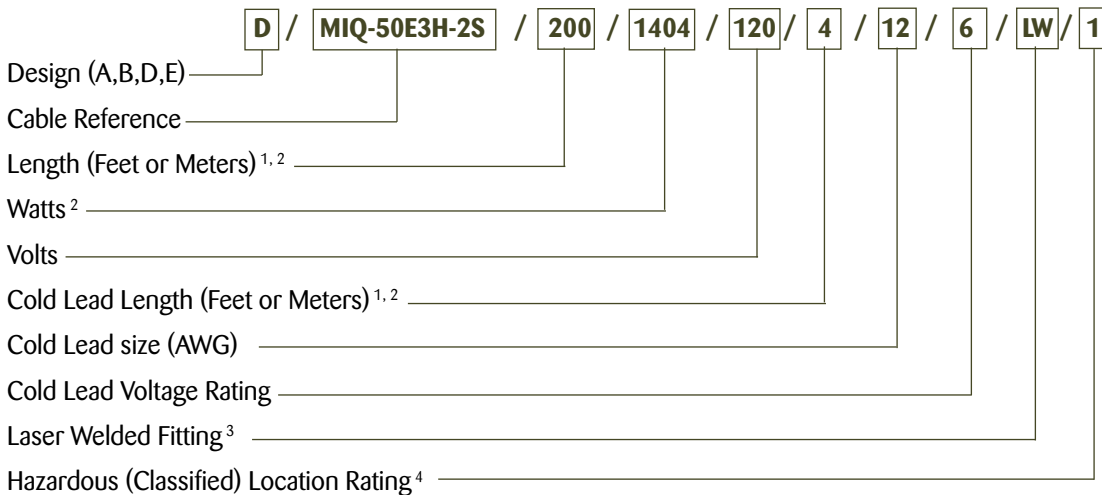

Notes . . .

1. The measurement in feet is standard. Metric lengths are followed by the letter "m".
2. For each installation, the vendor is to provide the design parameters for an engineered system which will designate the cable length, the total cable wattage, and the cold lead length for a specific application.
3. If the field is blank, then the heating cable set utilizes silver braze connections.
4. If the field is blank, then the heating cable set is intended for ordinary (non-classified) or Division 2 locations, or for use with AEx e or Ex e enclosures. If the value in the field is "1", then the heating cable set is intended for use in Division 1 locations, or for use with AEx d, or Ex d enclosures.



The Heat Tracing Specialists®

INSTALLATION PROCEDURES

Available MIQ Cables . . .

300 Vac Cable—Two Conductor—Heater Set Type D or E

Catalog Number	Resistance ¹		Nominal Diameter	
	ohms/ft	ohms/m	in	mm
MIQ-11E0L-2S	11.0	36.1	0.160	4.1
MIQ-90E1L-2S	9.0	29.5	0.160	4.1
MIQ-75E1L-2S	7.5	24.6	0.160	4.1
MIQ-60E1L-2S	6.0	19.7	0.160	4.1
MIQ-50E1L-2S	5.0	16.4	0.160	4.1
MIQ-40E1L-2S	4.0	13.1	0.160	4.1
MIQ-32E1L-2S	3.20	10.5	0.160	4.1
MIQ-27E1L-2S	2.75	9.02	0.160	4.1
MIQ-25E1L-2S	2.50	8.20	0.160	4.1
MIQ-20E1L-2S	2.00	6.56	0.160	4.1
MIQ-17E1L-2S	1.70	5.58	0.160	4.1
MIQ-14E1L-2S	1.40	4.59	0.160	4.1
MIQ-10E1L-2S	1.00	3.28	0.165	4.2
MIQ-70E2L-2S	0.70	2.30	0.180	4.6
MIQ-50E2L-2S	0.50	1.64	0.190	4.8
MIQ-30E2L-2S	0.30	0.98	0.170	4.3
MIQ-25E2L-2S	0.25	0.82	0.170	4.3
MIQ-20E2L-2S	0.20	0.66	0.170	4.3
MIQ-15E2L-2S	0.15	0.49	0.175	4.4
MIQ-10E2L-2S	0.10	0.33	0.190	4.8
MIQ-70E3L-2S	0.070	0.230	0.205	5.2
MIQ-50E3L-2S	0.050	0.164	0.225	5.7

600 Vac Cable—Two Conductor—Heater Set Type D or E

Catalog Number	Resistance ¹		Nominal Diameter	
	ohms/ft	ohms/m	in	mm
MIQ-11E0H-2S	11.0	36.1	0.205	5.2
MIQ-90E1H-2S	9.0	29.5	0.225	5.7
MIQ-60E1H-2S	6.0	19.7	0.230	5.8
MIQ-40E1H-2S	4.0	13.1	0.240	6.1
MIQ-20E1H-2S	2.00	6.56	0.255	6.5
MIQ-10E1H-2S	1.00	3.28	0.255	6.5
MIQ-70E2H-2S	0.70	2.30	0.265	6.7
MIQ-50E2H-2S	0.50	1.64	0.280	7.1
MIQ-30E2H-2S	0.30	0.98	0.300	7.6
MIQ-20E2H-2S	0.20	0.66	0.255	6.5
MIQ-15E2H-2S	0.15	0.49	0.265	6.7
MIQ-10E2H-2S	0.10	0.33	0.280	7.1
MIQ-70E3H-2S	0.070	0.230	0.295	7.5
MIQ-50E3H-2S	0.050	0.164	0.310	7.9
MIQ-40E3H-2S	0.040	0.131	0.325	8.3
MIQ-30E3H-2S	0.030	0.098	0.345	8.8
MIQ-20E3H-2S	0.020	0.066	0.270	6.9
MIQ-16E3H-2S	0.016	0.052	0.280	7.1
MIQ-13E3H-2S	0.013	0.043	0.290	7.4
MIQ-10E3H-2S	0.0104	0.0341	0.300	7.6
MIQ-81E4H-2S	0.00818	0.02684	0.300	7.6

600 Vac Cable—One Conductor—Heater Set Type A or B

Catalog Number	Resistance ¹		Nominal Diameter	
	ohms/ft	ohms/m	in	mm
MIQ-20E1H-1S	2.00	6.56	0.170	4.3
MIQ-16E1H-1S	1.60	5.25	0.170	4.3
MIQ-13E1H-1S	1.30	4.27	0.170	4.3
MIQ-10E1H-1S	1.00	3.28	0.170	4.3
MIQ-85E2H-1S	0.85	2.79	0.170	4.3
MIQ-70E2H-1S	0.70	2.30	0.170	4.3
MIQ-50E2H-1S	0.50	1.64	0.170	4.3
MIQ-38E2H-1S	0.38	1.25	0.170	4.3
MIQ-30E2H-1S	0.30	0.98	0.170	4.3
MIQ-25E2H-1S	0.25	0.82	0.170	4.3
MIQ-20E2H-1S	0.20	0.66	0.175	4.4
MIQ-17E2H-1S	0.17	0.56	0.180	4.6
MIQ-15E2H-1S	0.15	0.49	0.170	4.3
MIQ-10E2H-1S	0.10	0.33	0.170	4.3
MIQ-80E3H-1S	0.080	0.262	0.170	4.3
MIQ-70E3H-1S	0.070	0.230	0.170	4.3
MIQ-60E3H-1S	0.060	0.197	0.170	4.3
MIQ-40E3H-1S	0.040	0.131	0.175	4.4
MIQ-30E3H-1S	0.030	0.098	0.185	4.7
MIQ-20E3H-1S	0.020	0.066	0.200	5.1
MIQ-10E3H-1S	0.010	0.03395	0.170	4.3
MIQ-65E4H-1S	0.00651	0.02135	0.180	4.6
MIQ-40E4H-1S	0.00409	0.01342	0.190	4.8
MIQ-25E4H-1S	0.00258	0.00846	0.210	5.3
MIQ-16E4H-1S	0.00162	0.00531	0.225	5.7



DO NOT connect power to heating cable while it is in the shipping carton.

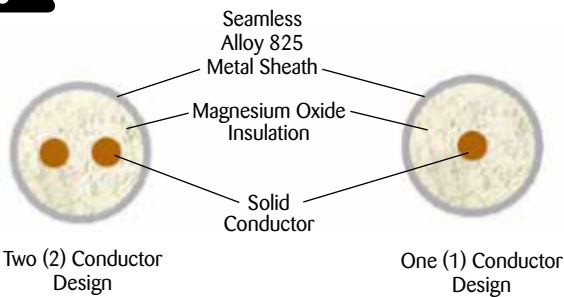

Heater Set Types . . .

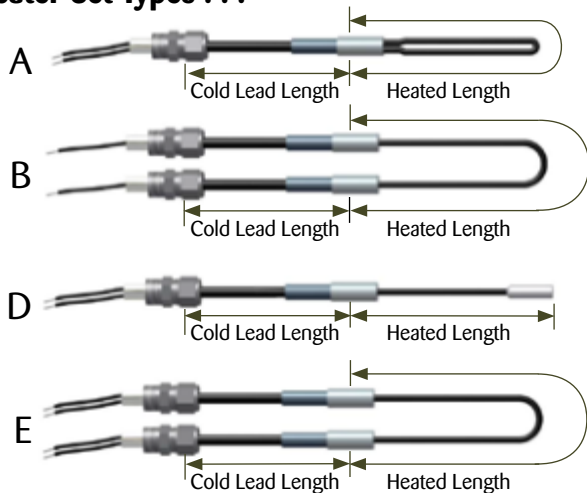

Note

1. All resistances shown are per length of cable at 68°F (20°C) and are subject to a ±10% manufacturing tolerance.

MIQ™ Mineral Insulated Heating Cable

Heating Cable Installation General Information

1. Identify the heating cable to ensure the proper type and quantity have been received. Factory-fabricated series circuits will have an imprinted I.D. tag with pertinent data. Compare information on heating cable with packing slip and purchase order to verify receipt of correct shipment.
2. Visually inspect materials for damage incurred during shipment.
3. Store in clean dry place. MIQ cable set cold lead ends must be kept dry before, during, and after installation.
4. Do not connect power to heating cable while in shipping carton or before installed on pipe/vessel.
5. Test insulation resistance of heating cable set when received, when installed with pipe uninsulated and after thermal insulation has been installed. Using a 500 Vdc megohmmeter the minimum acceptable reading is 20 megohms between conductor and metallic sheath. Use of a 1000 Vdc megohmmeter is recommended. After the application of thermal insulation the measured value should not be less than 5 megohms.

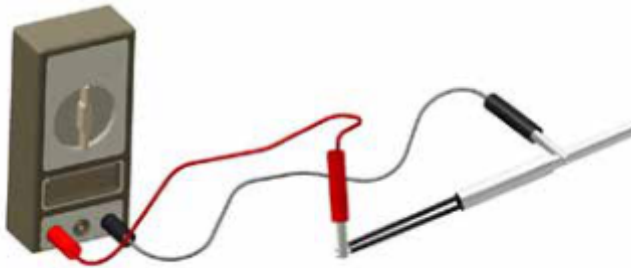

6. Heating cables shall not touch, cross over, or overlap itself after installation.
7. Metal structures or material used for the support of or on which cables are sets are installed, are to be grounded in accordance with applicable codes.
8. Minimum installation temperature is -76°F (-60°C).
9. Do not alter heating cable set length.
10. Do not remove metal tags from heating cable set.

11. Thermostat or solid state temperature control device must be used when the system T-rating relies on controlled designs to limit sheath temperature.
12. Heating cable must not be embedded in the thermal insulation.
13. Heating cable set shall be spaced at least 1/2" (13 mm) from any combustible surface.
14. MIQ cable set cold lead ends must be kept dry before, during and after installation.
15. Do not damage cable by repeatedly bending and straightening at same location.
16. Do not bend cable less than 6" (15 cm) away from hot to cold joint, splice, or end termination.
17. Minimum spacing between cable is 1" (25 mm) when installing multiple passes or loops.
18. The metal covering shall not be used as the bonding-to-ground means. Alternate means of protection shall be provided per applicable codes. The metal covering on this set and metal structures or materials used for the support of this set shall be grounded.
19. Provisions must be made to protect MIQ cable from welding slag, grinders, etc.
20. Keep lids on all power and splice junction boxes. Plug any unused entries.
21. Refer to Thermon Form TMP0006 for information on electrical safety precautions for electrical heat tracing.
22. At tee branch in a pipeline, particularly if the branch pipe is smaller than the main pipe, double tracing the smaller pipe with the main heating unit may cause unbalanced pipe temperature. Use caution, check schedules to see if permissible.
23. Any excess heating cable must be distributed evenly along pipe and equipment.
24. Junction boxes must be configured to exclude moisture. If applicable, all conduits feeding into the junction box shall be provided with appropriately rated drains to prevent moisture migration into the junction box.
25. **WARNING:** Explosion hazard. Do not install in environments having gas or vapour-air mixtures with an ignition temperature lower than temperature marked on the MI heating cable set tag.



The Heat Tracing Specialists®

INSTALLATION PROCEDURES

Before Installing Cable . . .

1. Be sure all piping and equipment to be traced is completely installed and pressure tested.
2. Surface areas where heat tracing is to be installed must be reasonably clean. Remove dirt, rust and scale with a wire brush and oil and grease films with a suitable solvent.
3. Review any applicable local codes and standards prior to beginning the installation.
4. Refer to heat tracing isometric drawings for power point location, equipment allowances, etc. Confirm if MIQ sets are to be connected in series.
5. Confirm measurements of piping length, including in-line equipment before beginning installation.

Initial Installation . . .

1. Determine the orientation of the heating cable(s) on the pipe. The upper 90° of the pipe should be avoided to minimize the possibility of mechanical damage to the heating cable. Also, the sides of the pipe should be avoided since this is the normal location of the insulation seams. Refer to Illustration B for typical heating cable orientations.
2. Begin temporary installation at the proposed hot-to-cold junction (power end) location and lay out heating circuit on the pipe. Refer to Illustration A for temporary installation.
3. Make heating cable allowances for valves, flanges, elbows and supports as per the applicable drawings and table on pages 5 thru 7 of these installation procedures.
4. Fix hot-to-cold junction at 6" (15 cm) distance on both sides using stainless steel tie wire or banding. Do not loop back cold lead on small diameter pipes where the minimum bending radius will be exceeded.
5. Install cable with slight "wave" on pipe. Secure cable to pipe with stainless steel tie wire or banding.
6. Adjust cable where necessary.

Illustration A: Temporary Installation . . .

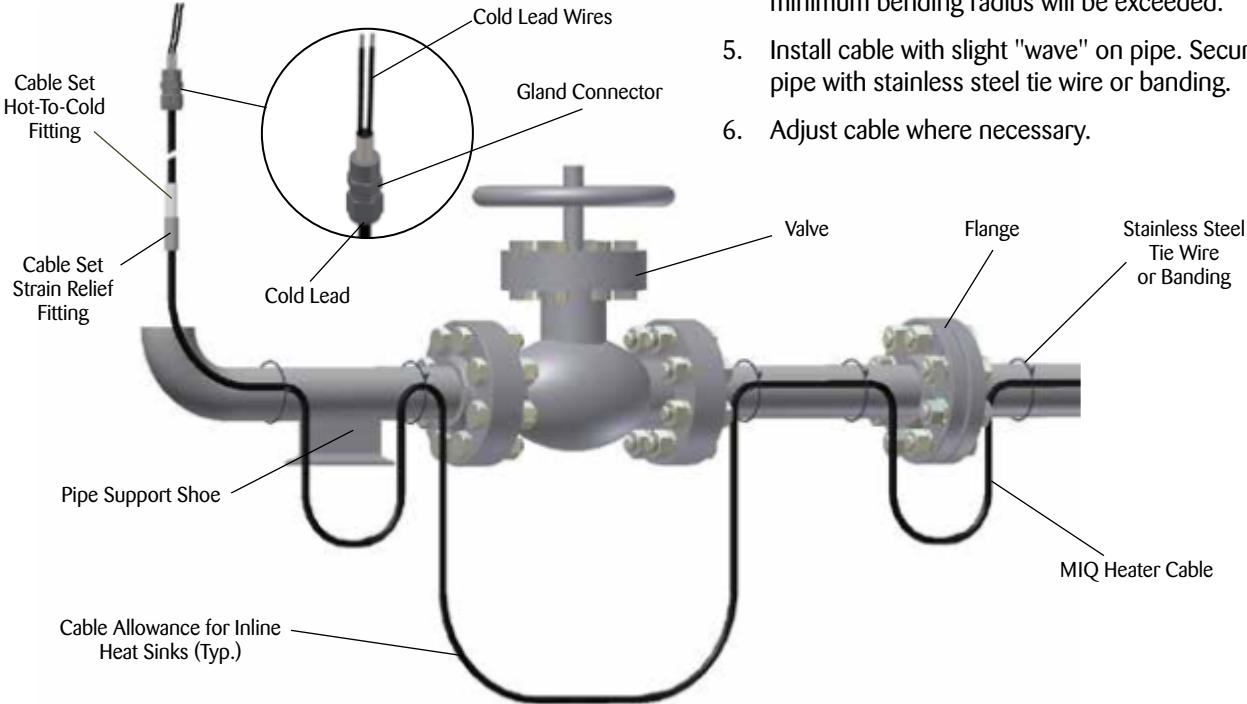
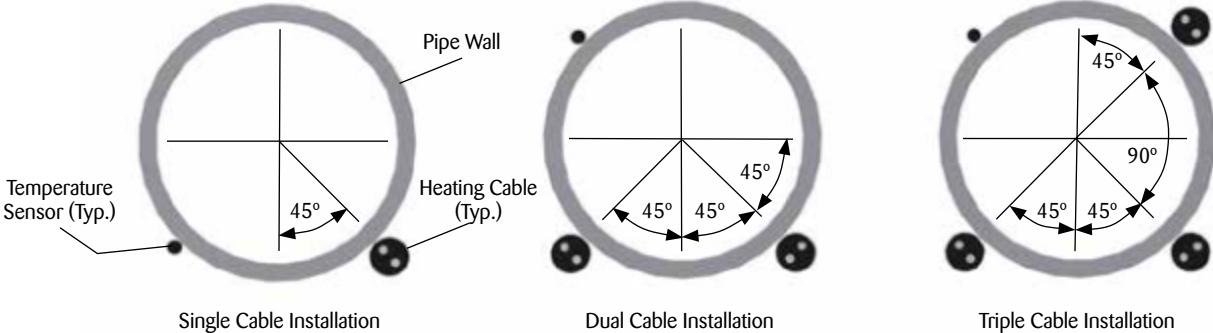

Illustration B: Typical Orientation of Heating Cable and Sensor Location . . .



MIQ™ Mineral Insulated Heating Cable

Installation on Elbows, Supports and Flanges . . .

1. Install heating cable in accordance with Illustrations C thru E below. Secure heating cable to piping using stainless steel tie wire or banding.
2. Elbows: Locate the cable on the outside radius of an elbow to provide sufficient heat to compensate for the added piping material. Secure the cable to the pipe on each side of the elbow with stainless steel tie wire or banding.
3. Pipe Supports: Insulated pipe supports require no additional heating cable. For uninsulated supports, allow two times the length of the pipe support plus an additional 15" (40 cm) of heating cable.

Illustration C: Pipe Elbow . . .

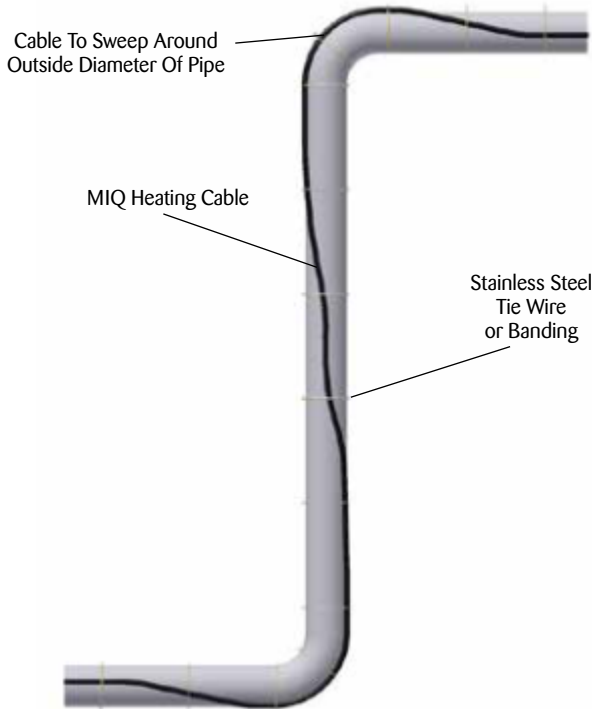

NOTE:
Slack cable can be taken up by running the cable on the outside radius of the pipe elbows. Running the cable on the inside radius of the pipe elbows will add slack to the cable.

4. Flanges: Heating cable should maintain contact with flange when bending around pipe flanges to compensate for additional heat loss. In potentially explosive areas, it is recommended to secure MIQ cable with stainless steel banding at all flanges or any other irregular shaped equipment.
5. Minimum bend radius is 6X cable OD. Do not exceed bend radius when completing installation.

Illustration D: Pipe Support . . .

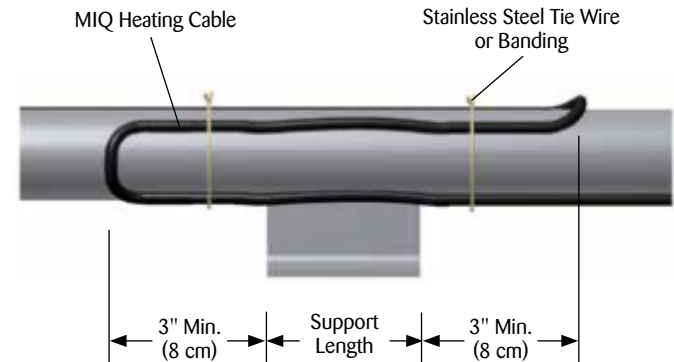

NOTE:
Loop cable 3 inches past pipe shoe support on both sides.

Illustration E: Pipe Flange . . .



Table 1 Flange Allowance (pair) . . .

Flange Size	IN	1/2	3/4	1	1 1/4	1 1/2	2	3	4	6	8	10	12	14	16	18	20	24	30
	(mm)	(12)	(19)	(25)	(32)	(40)	(50)	(80)	(100)	(150)	(200)	(250)	(300)	(350)	(400)	(450)	(500)	(600)	(750)
Flange Allowance	IN	6	7	7	7	8	8	10	11	12	13	14	16	18	19	20	21	24	26
	(mm)	(150)	(180)	(180)	(180)	(205)	(205)	(255)	(280)	(305)	(330)	(356)	(406)	(457)	(483)	(508)	(533)	(610)	(660)

INSTALLATION PROCEDURES

Installation on Valves and Pumps . . .

1. Install heating cable in accordance with Illustrations F and G below. Secure heating cable to piping using stainless steel tie wire or banding.
2. Additional cable is required to provide extra heat at valves, pumps and miscellaneous equipment to offset the increased heat loss associated with these items. Refer to Table 2 for estimated cable requirements for installation on typical valves and pumps.
3. Install heating cable on valves and pumps utilizing a looping technique (this allows the valve or pump to be removed if required). Do not cross cable.
4. Minimum bend radius is 6X cable O.D. Do not exceed bend radius when completing installation.
5. In potentially explosive areas, it is recommended to secure MIQ cable with stainless steel banding at all flanges, valves or any other irregular shaped equipment.

Illustration F: Typical Valve Detail . . .

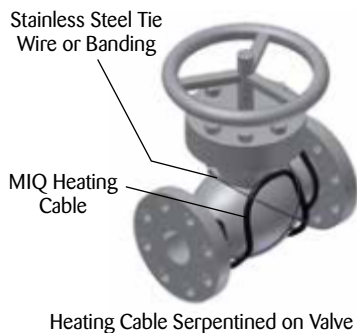
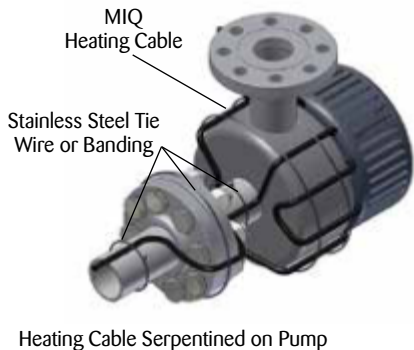

Illustration G: Typical Pump Detail . . .



NOTE: Individual MIQ cable set recommended for pumps.

Table 2: Valve and Pump Allowances

Pipe Size in (mm)	Valve Type			Pump Type	
	Screwed or Welded ft (m)	Flanged ft (m)	Butterfly ft (m)	Screwed ft (m)	Flanged ft (m)
½ (12)	.5 (.15)	1 (.30)	0	1 (.30)	2 (.61)
¾ (19)	.75 (.23)	1.5 (.46)	0	1.5 (.46)	3 (.91)
1 (25)	1 (.30)	2 (.61)	1 (.30)	2 (.61)	4 (1.22)
1¼ (32)	1.5 (.46)	2 (.61)	1 (.30)	3 (.91)	4.5 (1.37)
1½ (40)	1.5 (.46)	2.5 (.76)	1.5 (.46)	3 (.91)	5 (1.52)
2 (50)	2 (.61)	2.5 (.76)	2 (.61)	4 (1.22)	5.5 (1.68)
3 (80)	2.5 (.76)	3.5 (1.07)	2.5 (.76)	5 (1.52)	7 (2.13)
4 (100)	4 (1.22)	5 (1.52)	3 (.91)	8 (2.44)	10 (3.05)
6 (150)	7 (2.13)	8 (2.44)	3.5 (1.07)	14 (4.27)	16 (4.88)
8 (200)	9.5 (2.90)	11 (3.35)	4 (1.22)	19 (5.79)	22 (6.71)
10 (250)	12.5 (3.81)	14 (4.27)	4 (1.22)	25 (7.62)	28 (8.53)
12 (300)	15 (4.57)	16.5 (5.03)	5 (1.52)	30 (9.14)	33 (10.06)
14 (350)	18 (5.49)	19.5 (5.94)	5.5 (1.68)	36 (10.97)	39 (11.89)
16 (400)	21.5 (6.55)	23 (7.01)	6 (1.83)	43 (13.11)	46 (14.02)
18 (450)	25.5 (7.77)	27 (8.23)	6.5 (1.98)	51 (15.54)	54 (16.46)
20 (500)	28.5 (8.69)	30 (9.14)	7 (2.13)	57 (17.37)	60 (18.29)
24 (600)	34 (10.36)	36 (10.97)	8 (2.44)	68 (20.73)	72 (21.95)
30 (750)	40 (12.19)	42 (12.80)	10 (3.05)	80 (24.38)	84 (25.60)

Notes . . .

1. The valve allowance given is the total amount of additional cable to be installed on the valve. If multiple tracers are used, total valve allowance may be divided among the individual tracers. The total valve allowance may be alternated among tracers for multiple valves in a heat trace circuit.
2. Allowances are for 150 pound valves. More cable is required for higher rated valves.
3. Refer to heat trace isometric drawing for project specific allowances.

MIQ™ Mineral Insulated Heating Cable

Illustration H: Pipe Hanger . . .

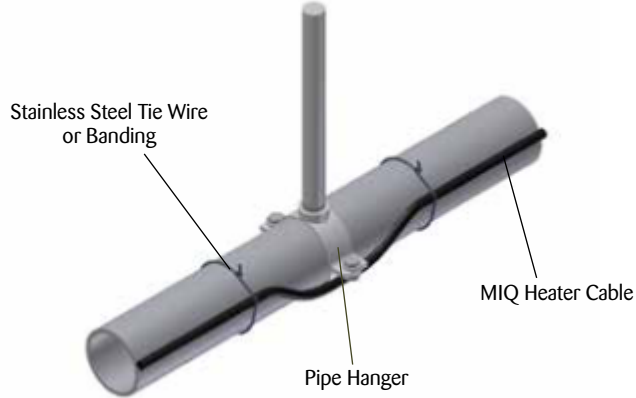
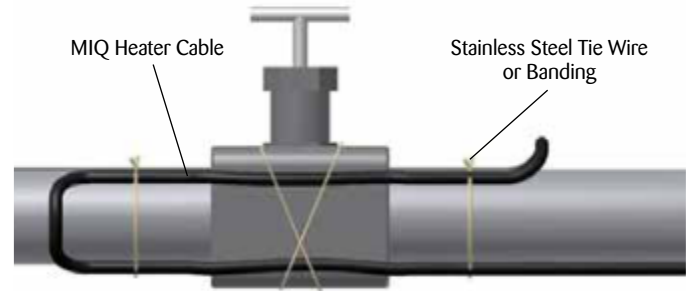

Illustration I: Socket Weld Valve . . .



Notes . . .

1. For small valves (less than 2") it may be impractical to install the correct cable allowance on the valve body itself. It can be installed in a uniform manner across the valve and either side of the pipe as shown above . . .
2. At tee branch pipe line (less than 2") if the branch pipe is double traced and the main pipe is single traced, then there is no additional requirement for cable allowance for valve.

Installation on Tanks and Vessels . . .

Always install MIQ cable longitudinally on surface of tanks or vessels. Never spiral wrap MIQ around circumference of tanks or vessels.



The Heat Tracing Specialists®

INSTALLATION PROCEDURES

Completing the Installation . . .

1. Begin final cable attachment by securing the end of circuit and working back toward the power supply.
 - MIQ mineral insulated heating cables are typically installed with tie wires or stainless steel banding at 12" (30 cm) intervals. Use only Thermon approved banding. Do not over tighten banding or tie wire. These cables may also be installed with heat transfer compound and metal channels.
 - If applicable, refer to installation details provided with the project drawings or contact TC-E for additional information regarding installation.
2. Before making power connections, the MIQ cable should be tested to ensure electrical integrity with at least a 500 Vdc megohmmeter (megger) between the conductors and the metal sheath. IEEE 515 recommends test voltage of 1000 Vdc for mineral insulated cable. Minimum resistance should be 20 megohms.
3. MIQ series resistance heating circuits are typically prefabricated at the factory. Junction boxes to complete a typical MIQ circuit connection to power may not be supplied as part of the system. For Ex d and AEx d sets, use only Ex d connection fittings. For Ex de and AEx de sets, use only Ex e connection fittings. Refer to Installation instructions included with power/splice enclosures or contact TC-E for additional information.
4. Route MIQ cable set cold lead(s) into junction box hub(s). Slowly tighten gland connector with set of wrenches until ferrule begins to make positive contact with cold lead sleeve and cold lead can not be moved by hand. Then tighten fitting 1/8 additional turn.
5. Secure temperature sensor (if required) to pipe utilizing stainless steel banding. Locate temperature sensor as shown in Illustration B.

Illustration J: Typical Installation . . .

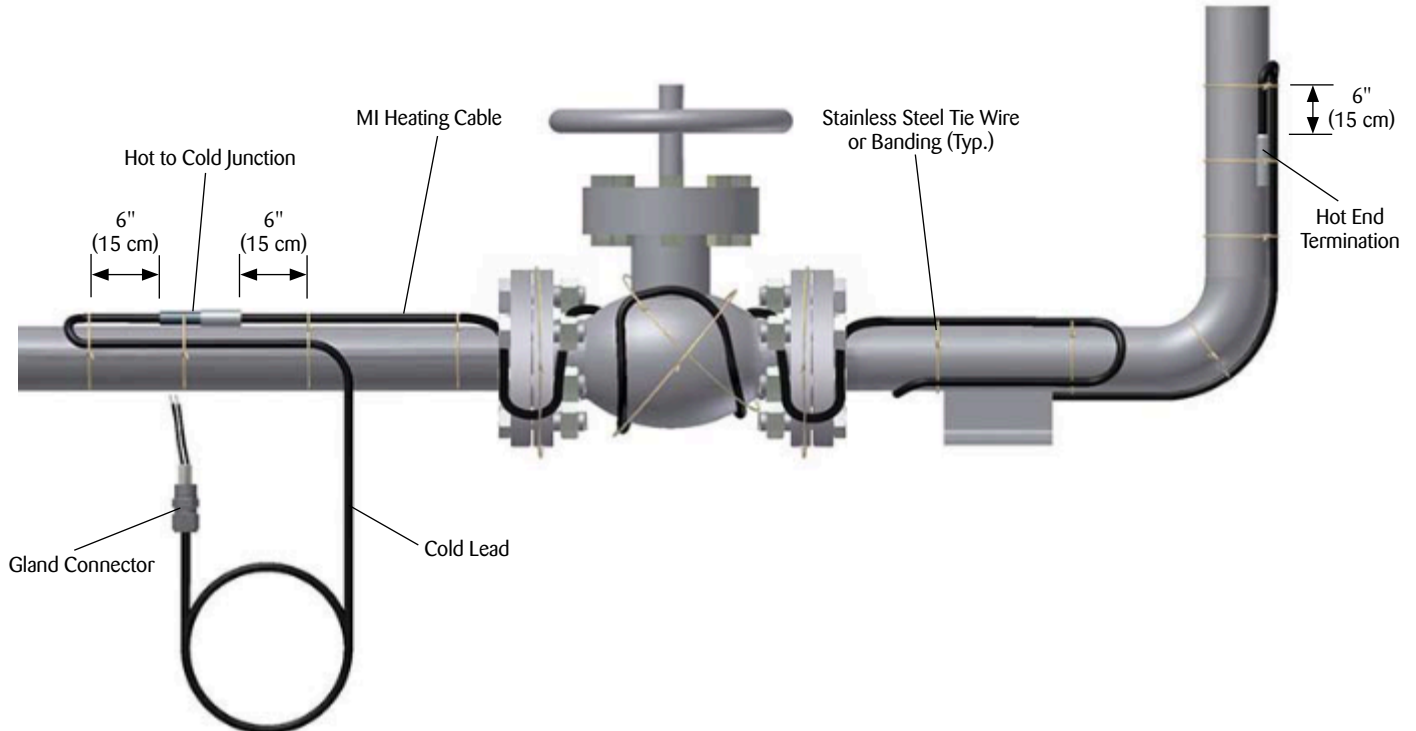

MIQ™ Mineral Insulated Heating Cable

Thermal Insulation . . .

1. The need for properly installed and well-maintained thermal insulation cannot be overemphasized. Without insulation, heat losses are generally too high to be offset by a conventional heat tracing system.
2. In addition to piping and in-line equipment such as pumps and valves, all heat sinks must be properly insulated. This includes pipe supports, hangers, flanges and, in most cases, valve bonnets.
3. Regardless of the type or thickness of insulation used, a protective barrier should be installed. This protects the insulation from moisture intrusion, physical damage and helps ensure the proper performance of the heat tracing system. Seal around all penetrations through the thermal insulation.
4. After the installation of the thermal insulation and weather barrier but **BEFORE ENERGIZING THE HEATING CIRCUIT**, the megohmmeter test should be repeated. The measured value should not be less than 5 megohms. This should call attention to any damage to the heating cable that may have occurred during the insulation installation.
5. Apply caution labels to insulation weather barrier at required intervals along pipe.

Final Inspection and Documentation . . .

1. It is recommended that the circuit be temporarily energized so that the volts, amps, pipe temperature and ambient temperature may be recorded. This information may be of value for future reference and should be maintained for the historical operating data log.
2. A sample historical operating data log form is included in the Electric Heat Tracing Maintenance and Troubleshooting Guide, Thermon Form TEP0066.



The National Electric Code and Canadian Electrical Code require ground-fault protection be provided for branch circuits supplying electric heat tracing.



The Heat Tracing Specialists®

Receiving Inspection Test Report for MIQ Heating Cable Document "A"

Item	Heating Cable Tag Number	Heating Cable Catalog Number	Visual Check By	Date	Insulation Resistance Test By	Reading (M Ω)	Date	Remarks
1								
2								
3								
4								
5								
6								
7								
8								
9								
10								
11								
12								
13								
14								
15								
16								
17								
18								
19								
20								

Representative	Name	Signature	Date

Customer: _____
Project Reference: _____
Contractor: _____
Megohmmeter Voltage: _____



Insulation Test Report for MIQ Heating Cable Document "B"

Heating Cable Information		After Installation of Cable					After Thermal Insulation of Pipe/Cable					Remarks	
		Heating Cable Tag Number	Heating Cable Catalog Number	Visual Check By	Date	Insulation Resistance Test By	Reading (M Ω)	Date	Visual Check By	Date	Insulation Resistance Test By		Reading (M Ω)
1													
2													
3													
4													
5													
6													
7													
8													
9													
10													
11													
12													
13													
14													
15													
16													
17													
18													
19													
20													

Representative	Name	Signature	Date

Customer: _____
Project Reference: _____
Contractor: _____
Meagohmmeter Voltage: _____



Commissioning Test Report for MIQ Heating Cable Document "C"

Circuit Data						By Installation Contractor						
Item	Panel Number	Breaker Number	Heater Number	Line Number	Volts	Insulation Resistance Test By	Reading (M Ω)	Date	Amperage Test By	Amps	Date	Remarks
1												
2												
3												
4												
5												
6												
7												
8												
9												
10												
11												
12												
13												
14												
15												
16												
17												
18												
19												
20												

Representative	Name	Date

Customer: _____
Project Reference: _____
Contractor: _____
Megohmmeter Voltage: _____





The Heat Tracing Specialists®

With Design, Manufacturing, and Warehouse Facilities Worldwide.

TC-E B.V.

Buitendijks 37 • 3356 LX Papendrecht • The Netherlands

Phone: +31 (0)183 - 201088 • E-mail: sales@tc-e.nl

www.tc-e.nl

ISO 9001
REGISTERED

Specifications and information subject to change without notice. Form No. 50273-0113