



PRODUCT SPECIFICATIONS

MIQ™ MINERAL INSULATED CABLE

APPLICATION

MIQ high performance mineral insulated heating cables are used extensively for high temperature maintenance, high temperature exposure and/or high watt density applications which exceed the limitations of thermoplastic insulated cables. The resistance configurations available can provide tracing for pipes up to 1 mile (1.6 km) long from a single power supply point.

Thermon's MIQ mineral insulated cables are manufactured using Alloy 825, a high nickel/chromium alloy ideally suited for high temperature service that offers exceptional resistance to stress corrosion in chloride, acid, salt and alkaline environments.

MIQ cables are approved for use in ordinary (nonclassified) areas and hazardous (classified) areas.

RATINGS

Rated voltage ¹300 and 600 Vac
 Max. maintenance temperature ² 932°F (500°C)
 Max. continuous exposure temperature
 Power-off 1,112°F (600°C)
 Max. watt density ² up to 80 w/ft (262 w/m)
 Minimum installation temperature -76°F (-60°C)
 Minimum bend radius6 x cable O.D.

MIQ CATALOG REFERENCE NUMBER

A complete catalogue reference number includes the following components:

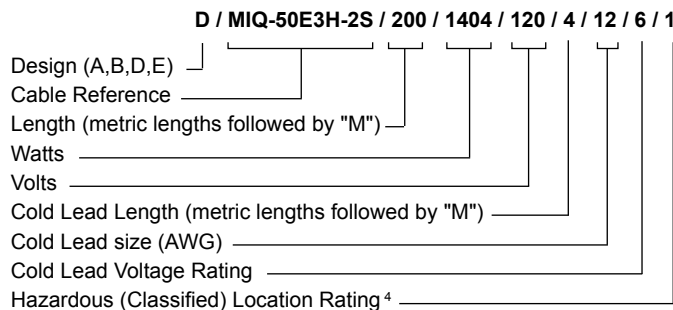

Notes

1. Definition as stated in IEEE Standard 515. Specific voltage depends on circuit length and design conditions.
2. Watt density limitations are correlated to maintain temperatures.
3. Contact TC-E for gland size information.
4. If the field is blank, then the heating cable set is intended for ordinary (non-classified) locations or Division 2 locations, or for use with AEx de, or Ex e enclosures. If the value in the field is "1", then the heating cable set is intended for Division 1 locations, or for use with AEx d, or Ex d enclosures.



CONSTRUCTION

- 1 Solid alloy or copper conductor(s)
- 2 Compacted magnesium oxide insulation
- 3 Seamless alloy 825 sheath

MIQ HEATER SETS

Thermon MIQ cable sets are available in four factory fabricated configurations: Type A, B, D or E. The standard assemblies consist of a predetermined length of heating cable joined to a standard 4' (1.2 m) or 7' (2.1 m) nonheating cold lead with 12" (305 mm) long thermoplastic insulated pigtails.

The nonheating section of the unit is sealed and fitted with a high pressure, liquid-tight 1/2" or 3/4" NPT stainless steel gland ³ for connection into the supply junction box.

Heater Set Types

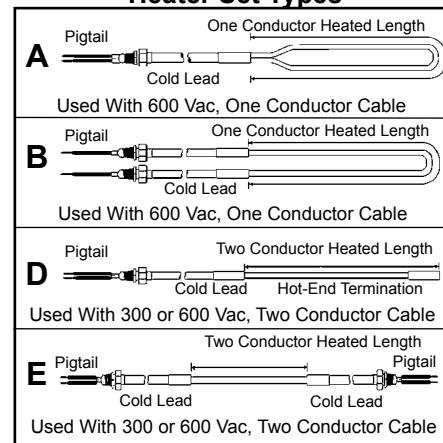

THERMON The Heat Tracing Specialists®

TC-E B.V. • Buitendijks 37 • 3356 LX Papendrecht • The Netherlands • Phone: +31 (0)183 - 201088 • E-mail: sales@tc-e.nl • www.tc-e.nl



AVAILABLE MIQ CABLES

600 Vac Cable—Two Conductor—Heater Set Type D or E

Catalog Number	Resistance ¹		Nominal Diameter	
	ohms/ft	ohms/m	in	mm
MIQ-11EOH-2S	11.0	36.1	0.225	5.2
MIQ-90E1H-2S	9.0	29.5	0.225	5.7
MIQ-60E1H-2S	6.0	19.7	0.230	5.8
MIQ-40E1H-2S	4.0	13.1	0.240	6.1
MIQ-20E1H-2S	2.00	6.56	0.255	6.5
MIQ-10E1H-2S	1.00	3.28	0.255	6.5
MIQ-70E2H-2S	0.70	2.30	0.265	6.7
MIQ-50E2H-2S	0.50	1.64	0.280	7.1
MIQ-30E2H-2S	0.30	0.98	0.300	7.6
MIQ-20E2H-2S	0.20	0.66	0.255	6.5
MIQ-15E2H-2S	0.15	0.49	0.265	6.7
MIQ-10E2H-2S	0.10	0.33	0.280	7.1
MIQ-70E3H-2S	0.070	0.230	0.295	7.5
MIQ-50E3H-2S	0.050	0.164	0.310	7.9
MIQ-40E3H-2S	0.040	0.131	0.325	8.3
MIQ-30E3H-2S	0.030	0.098	0.345	8.8
MIQ-20E3H-2S	0.020	0.066	0.270	6.9
MIQ-16E3H-2S	0.016	0.052	0.280	7.1
MIQ-13E3H-2S	0.013	0.043	0.290	7.4
MIQ-10E3H-2S	0.0104	0.0341	0.300	7.6
MIQ-81E4H-2S	0.00818	0.02684	0.300	7.6

600 Vac Cable—One Conductor—Heater Set Type A or B

Catalog Number	Resistance ¹		Nominal Diameter	
	ohms/ft	ohms/m	in	mm
MIQ-20E1H-1S	2.00	6.56	0.170	4.3
MIQ-16E1H-1S	1.60	5.25	0.170	4.3
MIQ-13E1H-1S	1.30	4.27	0.170	4.3
MIQ-10E1H-1S	1.00	3.28	0.170	4.3
MIQ-85E2H-1S	0.85	2.79	0.170	4.3
MIQ-70E2H-1S	0.70	2.30	0.170	4.3
MIQ-50E2H-1S	0.50	1.64	0.170	4.3
MIQ-38E2H-1S	0.38	1.25	0.170	4.3
MIQ-30E2H-1S	0.30	0.98	0.170	4.3
MIQ-25E2H-1S	0.25	0.82	0.170	4.3
MIQ-20E2H-1S	0.20	0.66	0.175	4.4
MIQ-17E2H-1S	0.17	0.56	0.180	4.6
MIQ-15E2H-1S	0.15	0.49	0.170	4.3
MIQ-10E2H-1S	0.10	0.33	0.170	4.3
MIQ-80E3H-1S	0.080	0.262	0.170	4.3
MIQ-70E3H-1S	0.070	0.230	0.170	4.3
MIQ-60E3H-1S	0.060	0.197	0.170	4.3
MIQ-40E3H-1S	0.040	0.131	0.175	4.4
MIQ-30E3H-1S	0.030	0.098	0.185	4.7
MIQ-20E3H-1S	0.020	0.066	0.200	5.1
MIQ-10E3H-1S	0.010	0.03395	0.170	4.3
MIQ-65E4H-1S	0.00651	0.02135	0.180	4.6
MIQ-40E4H-1S	0.00409	0.01342	0.190	4.8
MIQ-25E4H-1S	0.00258	0.00846	0.210	5.3
MIQ-16E4H-1S	0.00162	0.00531	0.225	5.7

300 Vac Cable—Two Conductor—Heater Set Type D or E

Catalog Number	Resistance ¹		Nominal Diameter	
	ohms/ft	ohms/m	in	mm
MIQ-11EOL-2S	11.0	36.1	0.160	4.1
MIQ-90E1L-2S	9.0	29.5	0.160	4.1
MIQ-75E1L-2S	7.5	24.6	0.160	4.1
MIQ-60E1L-2S	6.0	19.7	0.160	4.1
MIQ-50E1L-2S	5.0	16.4	0.160	4.1
MIQ-40E1L-2S	4.0	13.1	0.160	4.1
MIQ-32E1L-2S	3.20	10.5	0.160	4.1
MIQ-27E1L-2S	2.75	9.02	0.160	4.1
MIQ-25E1L-2S	2.50	8.20	0.160	4.1
MIQ-20E1L-2S	2.00	6.56	0.160	4.1
MIQ-17E1L-2S	1.70	5.58	0.160	4.1
MIQ-14E1L-2S	1.40	4.59	0.160	4.1
MIQ-10E1L-2S	1.00	3.28	0.165	4.2
MIQ-70E2L-2S	0.70	2.30	0.180	4.6
MIQ-50E2L-2S	0.50	1.64	0.190	4.8
MIQ-30E2L-2S	0.30	0.98	0.170	4.3
MIQ-25E2L-2S	0.25	0.82	0.170	4.3
MIQ-20E2L-2S	0.20	0.66	0.170	4.3
MIQ-15E2L-2S	0.15	0.49	0.175	4.4
MIQ-10E2L-2S	0.10	0.33	0.190	4.8
MIQ-70E3L-2S	0.070	0.230	0.205	5.2
MIQ-50E3L-2S	0.050	0.164	0.225	5.7

CIRCUIT BREAKER SIZING²

Maximum circuit lengths for various circuit breaker amperages are shown. Breaker sizing should be based on the National Electrical Code, Canadian Electrical Code or any other applicable code. The National Electrical Code and Canadian Electrical Code require ground-fault protection of equipment for each branch circuit supplying electric heating equipment. Check local codes for ground-fault protection requirements.

CERTIFICATIONS/APPROVALS



FM Approvals
 Ordinary Locations
 Hazardous (Classified) Locations
 Class I, Division 1 Groups B, C and D²
 Class I, Division 2, Groups A, B, C and D
 Class II, Divisions 1 and 2 Groups E, F and G
 Class III, Divisions 1 and 2
 Class I, Zone 1 AEx d IIC2
 Class I, Zone 1 AEx d IIC



Canadian Standards Association
 Ordinary Locations
 Hazardous (Classified) Locations
 Class I, Division 1, Groups B, C and D²
 Class I, Division 2, Groups A, B, C and D
 Class II, Divisions 1 and 2, Groups E, F and G
 Class III, Divisions 1 and 2
 Ex db IIC
 Ex db eb IIC

Notes

1. All resistances shown are per length of cable at 68°F (20°C) and are subject to a ±10% manufacturing tolerance.
2. Flameproof system must be specified, contact TC-E.