

**SnoTrace™ KSR™**  
**Surface Snow and Ice Melting**  
**INSTALLATION PROCEDURES**



**The Heat Tracing Specialists®**

# SnoTrace™ KSR™

## INSTALLATION PROCEDURES

Refer to the “SnoTrace KSR Cable Testing Report” for required recording of test data and circuit information.

### Upon Receiving Cable . . .

1. Upon receiving heating cable, check to make sure the proper type and output have been received. All cables are printed on the outer jacket with part number, voltage rating and watt output.
2. Visually inspect cable for any damage incurred during shipment. The heating cable should be tested to ensure electrical integrity with at least a 500 Vdc megohmmeter (megger) between the heating cable bus wires and the heating cable metallic braid. IEEE 515.1 recommends that the test voltage for polymer insulated heating cables be 2500 Vdc. Minimum resistance should be 20 megohms. (Record 1 on Cable Testing Report.)

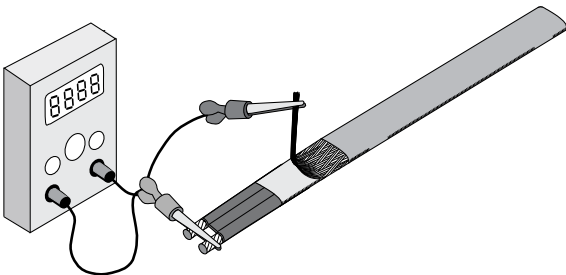

Connect the positive lead of the megger to the cable bus wires and the negative lead to the metallic braid.



**CAUTION:** DO NOT connect power to heating cable while it is on reel or in shipping carton.

### Installation of Cable . . .

1. Snow melting cable systems must be installed in accordance with the National Electrical Code, Canadian Electrical Code or any other applicable code. Review the requirements prior to installation.
2. Thermon recommends the heating cable junction boxes be placed adjacent to the edge of the slab, approximately 12” above grade, as shown on the illustration top right. If this is not feasible due to physical constraints of the installation, the cable can be routed through 1” minimum rigid metal conduit from the slab to the junction box. Only one heating cable per each conduit; Mechanical barriers or thermal insulation should be provided for any conduit that will be accessible to the public to ensure personnel safety.

Note: The entire length of the heating cable from the junction box to the slab, as well as the total length of cable installed inside the slab, should be used to determine the cable loading for that electrical circuit.

3. Locate and install the power connection/termination junction boxes as indicated in the KSR Design Guide or system installation drawings.

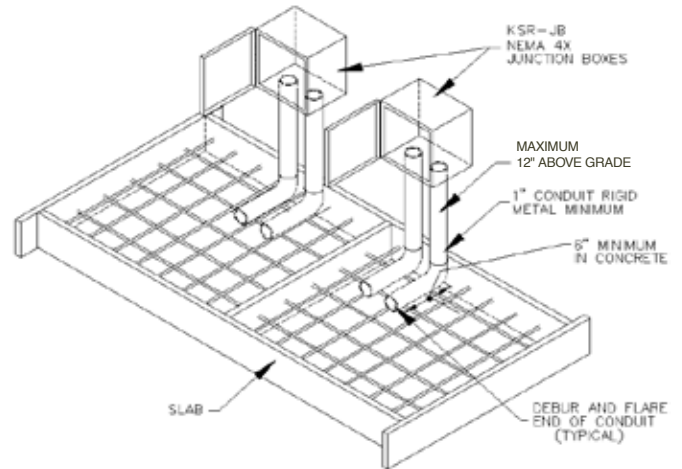

4. Route heater cable ends through rigid galvanized conduit into power/end termination box and temporarily fix both ends of the cable in the box. Leave at least 6” for terminations later.

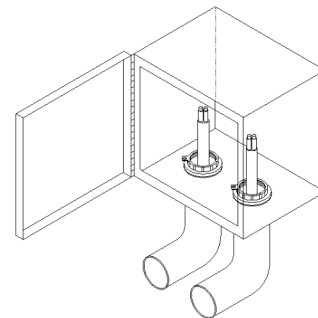

5. Lay out cable on top of rebar in a serpentine fashion beginning at the power box on centerline spacing as specified on project drawings. Bend cable in smooth arcs having a radius of no less than 2”. Avoid crossing expansion joints in the cable layout.

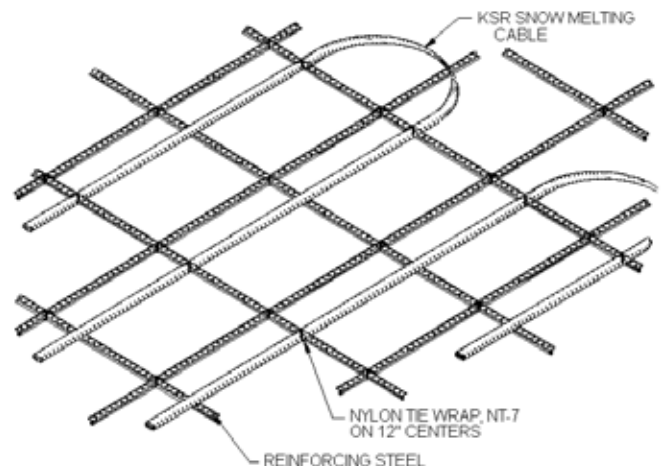

The Heat Tracing Specialists®

# SnoTrace™ KSR™

6. Cable layout must insure that both ends of cable end in the junction box (see example 1). If there is not enough cable to do so following the layout drawing, adjust the layout by shortening every other cable towards the center from the corners and ends slightly (see example 2). Contact TC-E prior to completion of installation should there be any discrepancies between the layout drawings and actual field conditions.

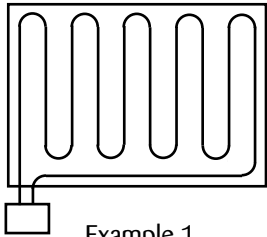

Example 1  
Designed Routing

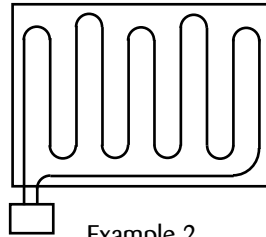

Example 2  
In Field, Solution

7. Where expansion joints must be crossed, KSR-EJK expansion joint kits are to be installed as shown below.

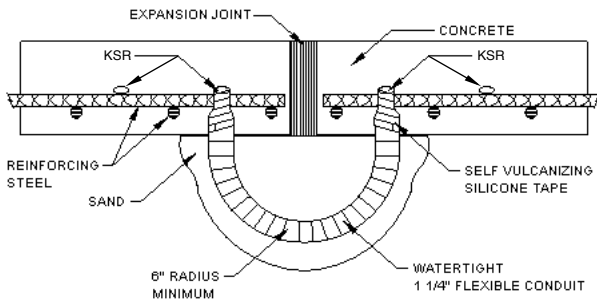

8. Attach cable with nylon tie straps on approximately 12" centers such that installed cable will be between 2" and 3" below the snow melting surface of the concrete.

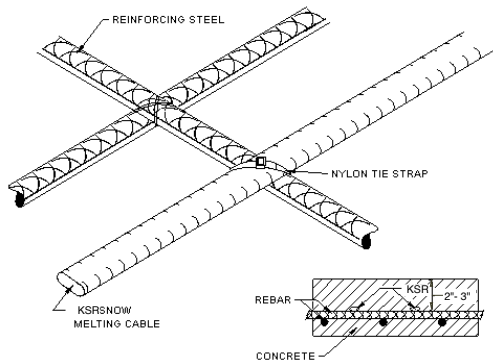

**DO NOT** Use metal wire to secure heating cable to rebar or steel mesh - electrical hazard and short circuits could result!



The Heat Tracing Specialists®

## Installation on Stairs . . .

1. Cable to be attached to rebar or wire mesh with nylon tie straps on approximately 18" centers such that installed cable will be between 2-1/2" to 3" below the snow melting surface of the stairs.
2. If dual pour used for construction of stairs, top cap must be minimum 2-1/2" thick. Corner of base pour must be removed where cable transitions from horizontal to vertical placement.

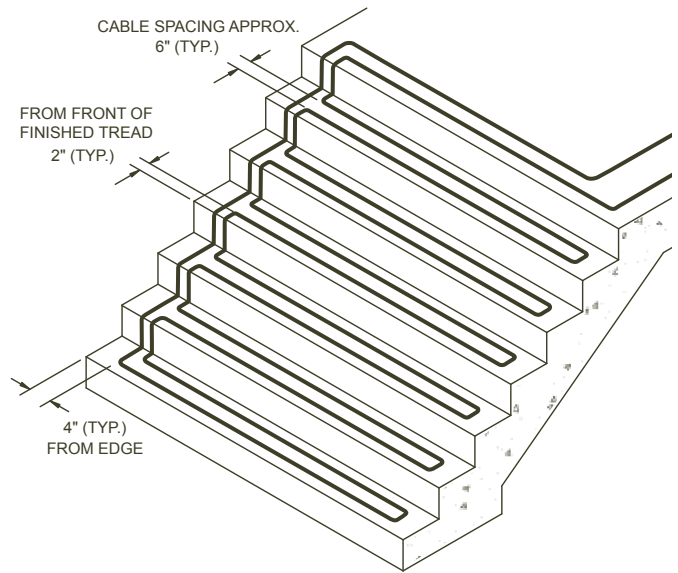

## Terminating the Heating Cable . . .

1. Upon completion of the cable layout recheck the spacing and ensure agreement with the specific project layout drawings. Check circuit length to insure length does not exceed maximum length provided in Design Guide.
2. Terminate the ends of the snow melting cable using a KSR-CFK circuit fabrication kit and the accompanying instruction sheets.

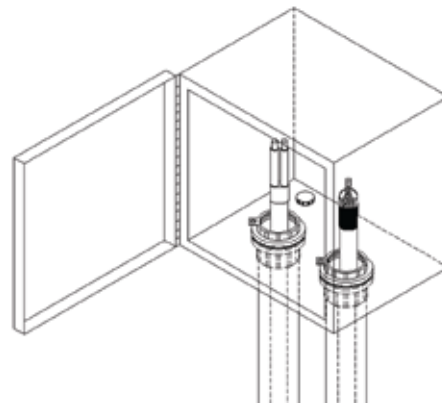

# INSTALLATION PROCEDURES

- Once the installation is complete, recheck the heating cable with at least a 500 Vdc megohmmeter (megger) between the heating cable bus wires and the heating cable metallic braid. IEEE 515.1 recommends that the test voltage for polymer insulated heating cables be 2500 Vdc. Minimum resistance should be 20 megohms. (Record 2 on Cable Testing Report.)
- Install appropriate grounding wires as shown and connect incoming power and ground wires to snow melting cable and ground system.

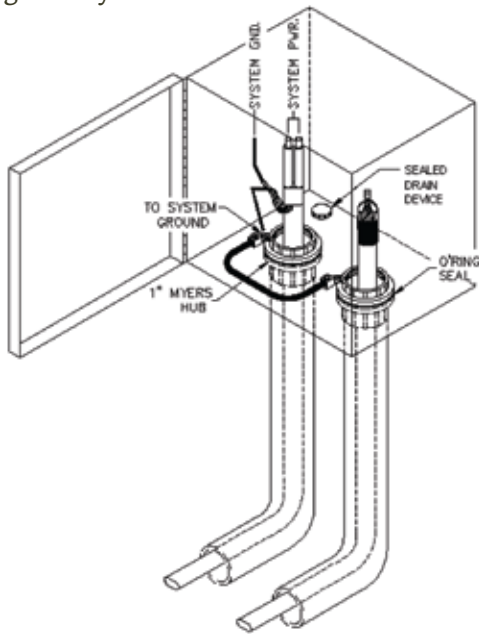

## Installation of Concrete . . .

- While pouring and finishing the concrete, the snow melting cable should be monitored for resistance between the ground and bus wires (should read 20 megohms or higher) throughout installation. (Record 3 on Cable Testing Report.)

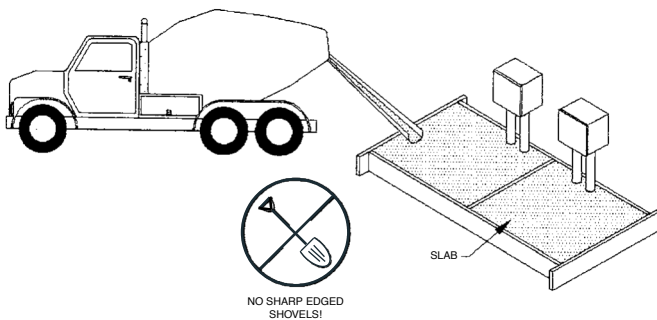

**IMPORTANT:** During the pour, care should be taken to minimize the chance of cutting or damaging the heating cable, causing short circuits.

The snow melt cable should not be energized for a minimum of 7 days after installation to ensure adequate slab cure.



**If the resistance test reading suddenly decreases, the heating cable has been damaged!!!**

- Immediately stop the pour and find the damaged section.
- Repair the damaged section with a KSR-SK Splice Kit.
- Failure to repair a damaged heating cable section during the pour may result in the entire snow melt circuit becoming inoperative.
- Once the damaged section is repaired, megger the cable again and record the results. If the reading exceeds 20 megohms, proceed with the pour. If the reading is below 20 megohms, look for another damaged section.
- Failure to follow cable test instructions and record test readings may void system warranty.

## Installing the Controls . . .

- Locate the snow sensor in a physically secure area representative of the environmental conditions to which the desired snow free area is to be exposed. Power the snow sensor control panel from a main distribution panel having a breaker(s) sized at a minimum of 20% over the maximum current draw specified. Breakers shall be of the 30 mA ground fault interrupting type. Reference Thermon Snow Sensor installation instructions for details.

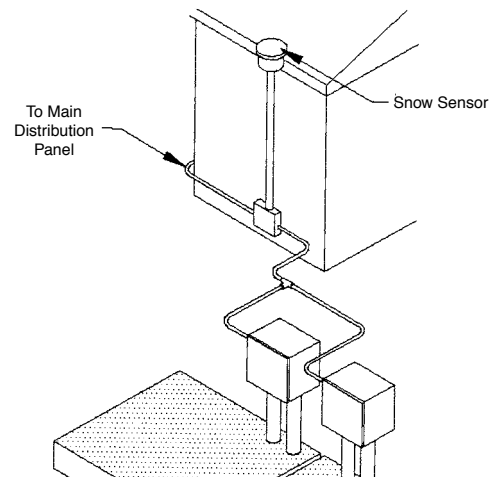

- Once power is connected but before putting the system into operation, verify all heating cable testing and documentation have been completed for each heat tracing circuit. This will ensure that the system has been installed per the manufacturers recommendations. (Record 4 on Cable Testing Report.)



The National Electric Code and Canadian Electrical Code require ground-fault protection be provided for branch circuits supplying electric heat tracing on fixed outdoor electric de-icing and snow-melting equipment.

## KSR for Snow Melting Under Asphalt Paving . . .

The following information is in addition to the standard installation guidelines and testing recommendations included in the KSR Installation Instructions.

With a maximum exposure temperature rating of 350°F (177°C), KSR cables can usually withstand the temperatures encountered during asphalt placement. Once it is verified that the asphalt application temperature is consistent with the KSR cable temperature rating, a structurally sound base should be in place for the heater cable attachment.

There are two recommended methods of attachment for asphalt installations: (1) a mesh is secured in place over the existing base and the cable is attached to the mesh with non-metallic ties or tape suitable for the asphalt temperature (such as 3M 69 tape), or (2) anchor bolts are secured to the existing base and the cable is attached to the anchors with non-metallic ties or tape. After the cables are secured in place and tested (Cable Testing Report Form), the asphalt should be spread manually over the cables, approximately 2" thick minimum then rolled with a hand roller.

**Design Note<sup>1</sup>:** for installation in asphalt, the output of KSR cables should be derated by a factor of 0.9, resulting in the following KSR Cable Spacing chart modifications:

**Design Note<sup>2</sup>:** Local regulations and codes should always be reviewed in advance for additional requirements; for example, CSA approvals for heating cables embedded in asphalt have a maximum spacing of 6" ..

### KSR Cable Spacing in Asphalt

Snowfall Severity		KSR Cable Spacing in Asphalt	
Category	Rate of Snowfall	Noncritical	Critical
Light	1/2" per hour	10"	6"
Moderate	1" per hour	8"	5"
Heavy	2" per hour	6"	5"

Please contact TC-E for additional information and design assistance

## KSR for Snow Melting Under Paving Stones . . .

The following information is in addition to the standard installation guidelines and testing recommendations included in the KSR Installation Instructions.

When installing KSR cable under paving stones, care should be taken to ensure the cables are secured in place between two layers of sand below the pavers. For typical 1-1/2" to 2" thick paving stones, the first sand layer should be 1-1/2" thick with the cable secured in place on top of this layer.

Do not use metallic tie wire to secure the cable in place.

Another layer of sand, 1-1/2" thick, should be layered on top of the cable prior to placement of the pavers.

Please contact TC-E for additional information and design assistance.



# SnoTrace™ KSR™ Cable Testing Report

1. Refer to Thermon KSR Installation Procedures, FORM CPD1030, for general installation procedures, requirements and guidelines.
2. Upon receiving heating cable, check the cable to make sure the proper type and output have been received. All cables are printed on the outer jacket with part number, voltage rating and watt output.

3. Visually inspect cable for any damage incurred during shipment. The heating cable should be tested to ensure electrical integrity with at least a 500 Vdc megohmmeter (megger) between the heating cable bus wires and the heating cable metallic braid. IEEE 515.1 recommends that the test voltage for polymer insulated heating cables be 2500 Vdc. Minimum resistance should be 20 megohms. **(Record 1 on Cable Testing Report.)**

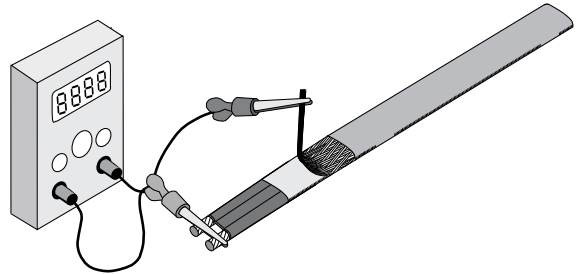

- A. Connect the positive lead of the megger to the cable bus wires.
  - B. Connect the negative lead of the megger to the metallic braid.
  - C. Energize the megger and record the reading. Readings between 20 megohms and infinity are acceptable. Readings below 20 megohms may mean the electrical insulation has been damaged. Recheck the heating cable for physical damage between the braid and the heating element; small cuts or scuffmarks on the outer jacket will not affect the megger reading unless there was actual penetration through the braid and dielectric insulation jacket.
4. Once the installation is complete, but prior to concrete pour, recheck the heating cable with at least a 500 Vdc megohmmeter (megger) between the heating cable bus wires and the heating cable metallic braid. IEEE 515.1 recommends that the test voltage for polymer insulated heating cables be 2500 Vdc. Minimum resistance should be 20 megohms. **(Record 2 on Cable Testing Report.)**
  5. While pouring and finishing the concrete, the cable should be monitored for resistance between the ground and bus wires using a megger throughout installation. If the resistance test reading suddenly decreases, the heating cable has been damaged!
    - Immediately stop the pour and find the damaged section.
    - Repair the damaged section with a SMT-SK Splice Kit.
    - Failure to repair a damaged heating cable section during the pour may result in the entire snow melt circuit becoming inoperative.
    - Once the damaged section is repaired, megger the cable again and record the results. If the reading exceeds 20 megohms, proceed with the pour. If the reading is below 20 megohms, look for another damaged section.
    - Failure to follow cable test instructions and record test readings may void system warranty.

After the concrete pour is completed, check resistance from bus wires to the metallic braid. Minimum resistance should be 20 megohms. **(Record 3 on Cable Testing Report.)**

6. The cable should not be energized for a minimum of 7 days after installation to ensure a complete slab cure. After the slab is cured and power supply is completed, record the panel and circuit breaker information. Ensure all junction boxes, temperature controllers, cable glands, etc. are properly secured. Set the temperature controller (if applicable) to the manual setting and apply rated voltage to the heat tracing circuit(s) for 10 minutes. Record the ambient temperature, measure and record the circuit(s) voltage and current. **(Record 4 on Cable Testing Report.)**

**NOTE: To ensure the heating cable warranty is maintained through installation, the testing outlined on this sheet must be completed on the installed heating cables, and the test results recorded and mailed/faxed to:**

Thermon Customer Service  
100 Thermon Drive  
San Marcos, Texas 78666  
Fax: 512-754-2420



# SnoTrace™ KSR™ Cable Testing Report

Customer: \_\_\_\_\_

Contractor: \_\_\_\_\_

Address: \_\_\_\_\_

Address: \_\_\_\_\_

Phone No: \_\_\_\_\_

Phone No. \_\_\_\_\_

Project Reference: \_\_\_\_\_

## Record 1: Prior to Installation

Cable Type: \_\_\_\_\_

Heater Length: \_\_\_\_\_

Heater Number: \_\_\_\_\_

Insulation Resistance M Ohms: \_\_\_\_\_

Tested By: \_\_\_\_\_

Date: \_\_\_\_\_

Witnessed By: \_\_\_\_\_

Date: \_\_\_\_\_

## Record 2: After Installation

Insulation Resistance M Ohms: \_\_\_\_\_

Tested By: \_\_\_\_\_

Date: \_\_\_\_\_

Witnessed By: \_\_\_\_\_

Date: \_\_\_\_\_

## Record 3: While Pouring Concrete

Insulation Resistance M Ohms: \_\_\_\_\_

Tested By: \_\_\_\_\_

Date: \_\_\_\_\_

Witnessed By: \_\_\_\_\_

Date: \_\_\_\_\_

## Record 4: Final Commissioning

Panel Number: \_\_\_\_\_

Breaker Number: \_\_\_\_\_

Volts: \_\_\_\_\_

Ambient Temperature (deg. F): \_\_\_\_\_

Recorded Amps: \_\_\_\_\_

Tested By: \_\_\_\_\_

Date: \_\_\_\_\_

Witnessed By: \_\_\_\_\_

Date: \_\_\_\_\_



TC-E B.V.

Buitendijks 37 • 3356 LX Papendrecht • The Netherlands  
Phone: +31 (0)183-201088 • E-mail: sales@tc-e.nl  
www.tc-e.nl

ISO 9001  
REGISTERED