

FAK-5 and FAK-5L

Tee Splice Kit for Tubing Bundles

INSTALLATION PROCEDURES

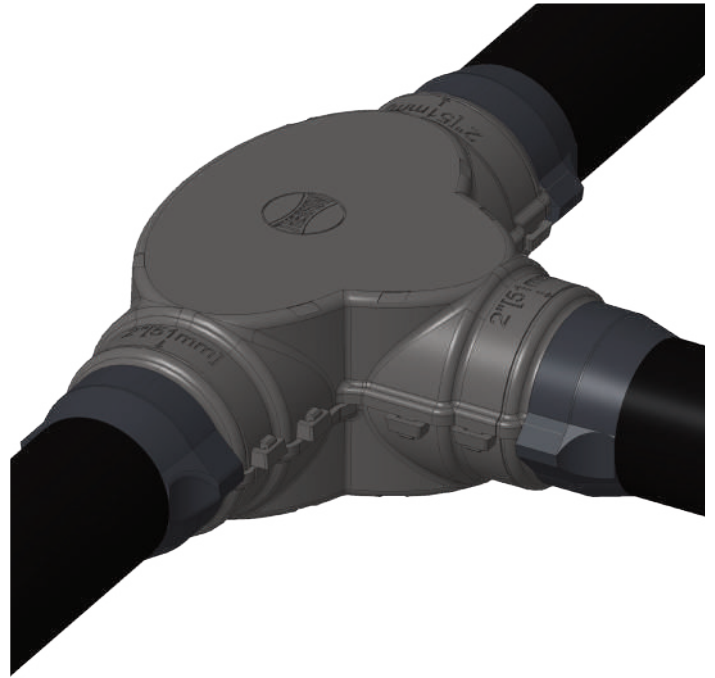

FAK-5 and FAK-5L

The FAK-5 and FAK-5L: Tee Splice Kits are designed to make a waterproof seal over the end of TubeTrace or ThermoTube at the splice connections. Review FAK-5 and FAK-5L instructions prior to installation. Kit will make one splice connection (Tube fittings not included). See separate instructions for details on splicing heating cables.

Receiving, Storing and Handling

1. Inspect materials for damage incurred during shipping.
2. Report damages to the carrier for settlement.
3. Identify parts against the packing list to ensure the proper type and quantity has been received.
4. Store in dry location.

FAK-5 and FAK-5L: Tee Splice Kit



FAK-5 and FAK-5L: Tee Splice Kit Contents

Item	Quantity	Description
1	1	Tee Splice Cover (Top)
2	1	Tee Splice Cover (Bottom)
3	1	Silicone Gasket
4	1	Self-Vulcanizing Tape
5	1	Heat Reflective Tape
6	1	Glass Fiber Tape
7	2 (FAK-5) 3 (FAK-5L)	RTV Sealant Tube

Dimensions

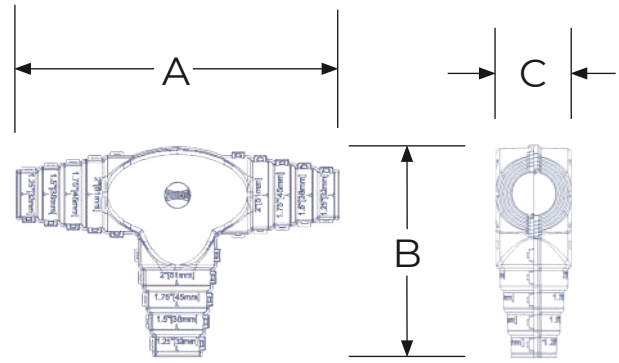

	A mm (inch)	B mm (inch)	C mm (inch)
FAK-5	279 mm (11")	181 mm (7-1/8")	64 mm (2-1/2")
FAK-5L	489 mm (19-1/4")	317 mm (12-1/2")	111 mm (4-3/8")

Installation Precautions

- To minimize the potential for arcing and ground-fault protection. The National Electrical Code (NEC) and Canadian Electrical Code (CEC) require ground-fault protection of equipment for each branch circuit supplying electric heat tracing.
- Installation must comply with Thermon requirements and be installed in accordance with the NEC, CEC, or any other applicable national and local codes.
- Component approvals and performance ratings are based on the use of Thermon specified parts only. User supplied power connection fittings must be listed or certified for intended use.
- De-energize all power sources before opening enclosure.
- Keep ends of heating cable and kit components dry before and during installation.
- Individuals installing these products are responsible for complying with all applicable safety and health guidelines. Proper personal protective equipment, or PPE, should be utilized during installation. Contact Thermon if you have any additional questions.

Tools Required



INSTALLATION PROCEDURES

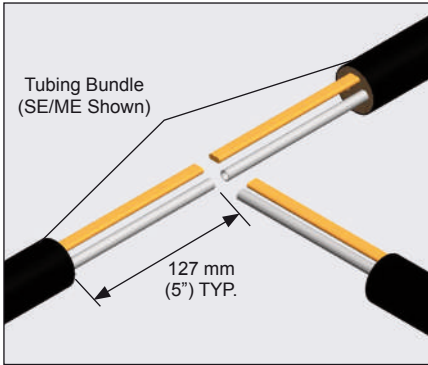

1. Remove outer jacket and insulation from tubing bundle approximately 127 mm (5") from end of the tubing bundle. Where required ensure sufficient heat trace is available for electrical splice. See instructions included with heat trace kit (purchased separately).



Do not cut or damage the heat trace.
(Found on TubeTrace SE/ME bundles)

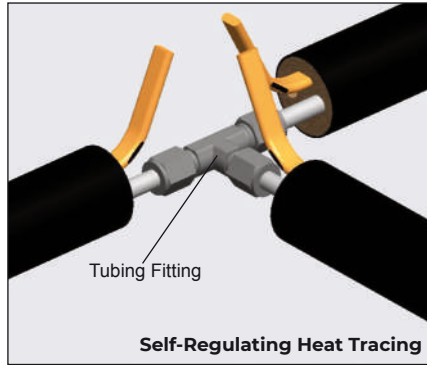

2. Cut 38 mm (1.5") off the end of the tubing and make tube fitting connections with appropriate fittings, provided by others. If no electrical heat trace is present, go to Step 4.

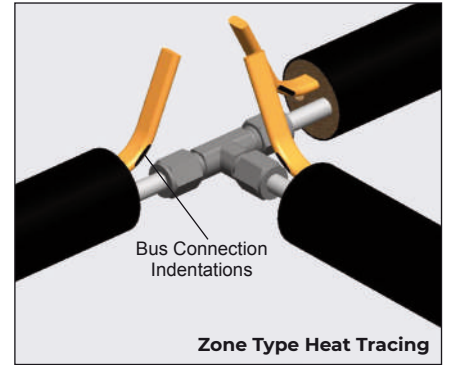

- 2a. If bus connection indentation is less than 38 mm (1.5") from end of the heat tracing, proceed stripping the bundle insulation to the next indentation.

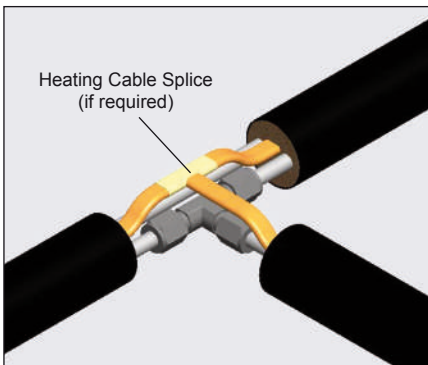

3. If bundle includes electric heat trace, make-up splice per instruction included with heater cable kit. This should be accomplished after fittings are leak tested.

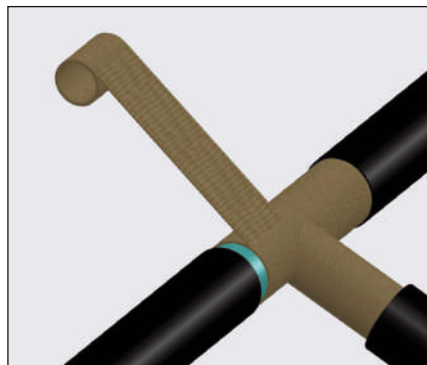

4. Wrap tube and heat trace with 1 pass of reflective tape (25% overlap), then wrap with 3 passes of glass fiber tape (50% overlap), or until fiber tape is equal to original bundle insulation thickness.

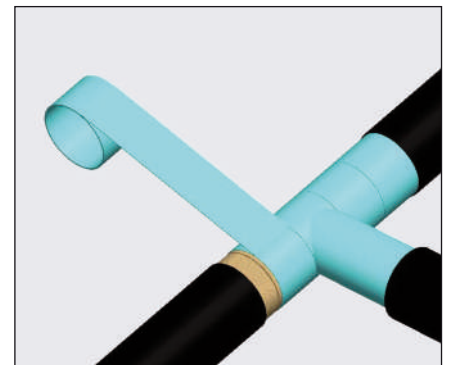

5. Complete with additional passes of heat reflective tape.

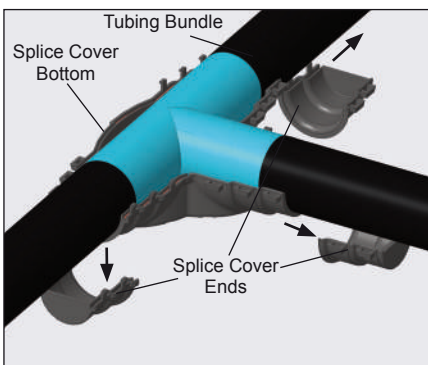

6. Cut top and bottom splice cover ends to match outside diameter of tubing bundle.

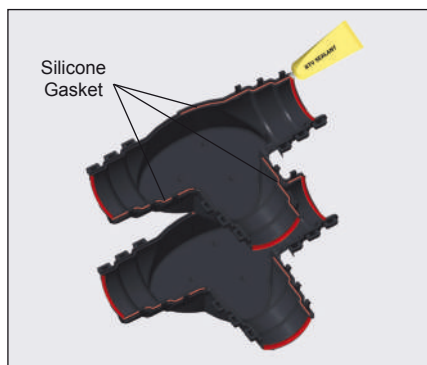

7. Install silicone gasket, cutting off excess. Apply RTV sealant to both halves.

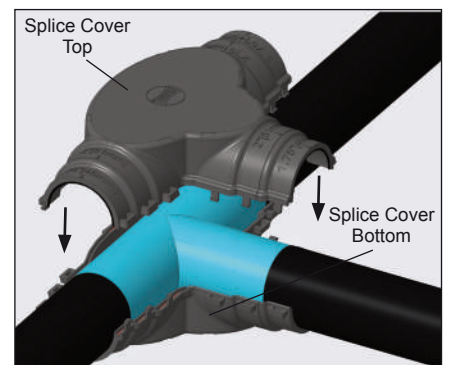

8. Fit tubing bundle to bottom half of cover and install top half. Snap together firmly. Inspect ends of tubing splice cover for snug fit. Apply additional RTV sealant where needed.

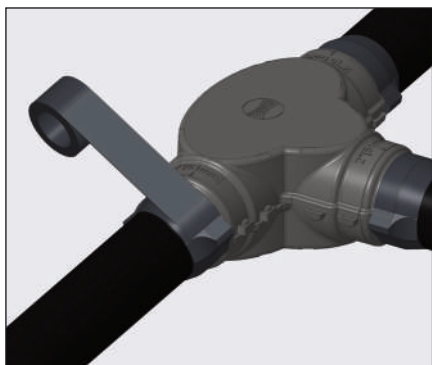

- 9.** Apply self-vulcanizing tape around bundle jacket and work up over FAK ends.

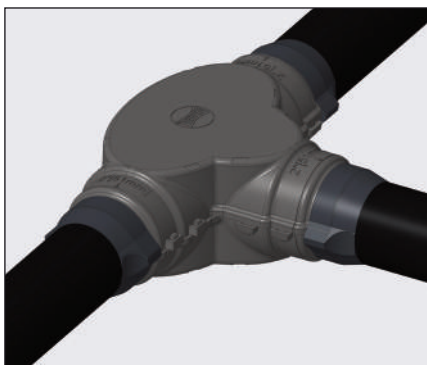

- 10.** Completed FAK-5/5L kit.

