

# **FAK-2 and FAK-2L**

Elbow Splice Kit for  
Tubing Bundles

## **INSTALLATION PROCEDURES**

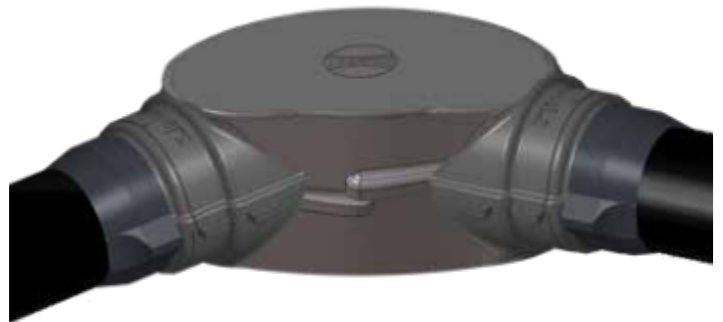

# FAK-2 and FAK-2L

The FAK-2 and FAK-2L Elbow Splice Kits are designed to make a waterproof seal over the end of TubeTrace or ThermoTube where a 90° elbow is required. Review instructions prior to installation. Kit will make one splice connection. See separate instructions for details on splicing heating cables.

### Receiving, Storing and Handling

1. Inspect materials for damage incurred during shipping.
2. Report damages to the carrier for settlement.
3. Identify parts against the packing list to ensure the proper type and quantity has been received.
4. Store in a dry location.

### FAK-2 and FAK-2L Elbow Splice Kit



### Kit Contents

Item	Quantity	Description
1	1	90° Elbow Splice Cover (Top)
2	1	90° Elbow Splice Cover (Bottom)
3	1	Heat Reflective Tape
4	1	Silicone Gasket
5	1	Glass Fiber Tape
6	2 (FAK-2) 3 (FAK-2L)	RTV Sealant Tube
7	1	Self-Vulcanizing Tape

### Dimensions

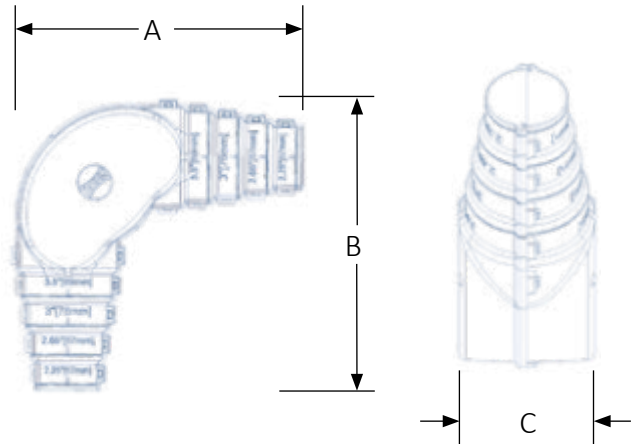

	A mm (inch)	B mm (inch)	C mm (inch)
FAK-2	187 mm (7-3/8")	187 mm (7-3/8")	64 mm (2-1/2")
FAK-2L	328 mm (12-7/8")	328 mm (12-7/8")	111 mm (4-3/8")

### Installation Precautions

- To minimize the potential for arcing and ground-fault protection. The National Electrical Code (NEC) and Canadian Electrical Code (CEC) require ground-fault protection of equipment for each branch circuit supplying electric heat tracing.
- Installation must comply with Thermon requirements and be installed in accordance with the NEC, CEC, or any other applicable national and local codes.
- Component approvals and performance ratings are based on the use of Thermon specified parts only. User supplied power connection fittings must be listed or certified for intended use.
- De-energize all power sources before opening enclosure.
- Keep ends of heating cable and kit components dry before and during installation.
- Individuals installing these products are responsible for complying with all applicable safety and health guidelines. Proper personal protective equipment, or PPE, should be utilized during installation. Contact Thermon if you have any additional questions.

### Tools Required



# INSTALLATION PROCEDURES

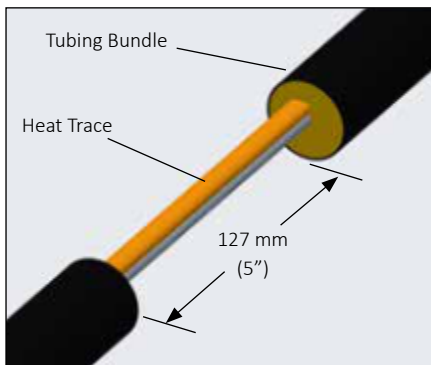

1. Remove approximately 127 mm (5") of outer jacket and insulation from tubing bundle.



**CAUTION**

If electrically heated, do not cut or damage the heat trace. (Found on TubeTrace SE/ME bundles)

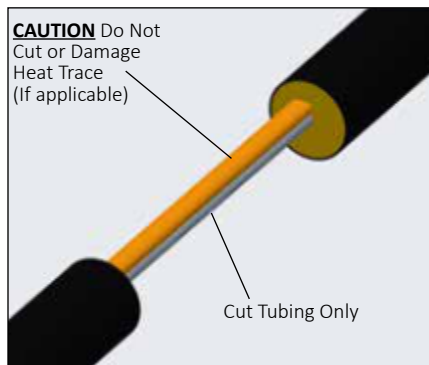

2. Cut tubing, being careful not to damage or cut the heating cable. For splicing two tube bundles, heater cable must be spliced. Order the appropriate Heat Trace Splice Kit separately.

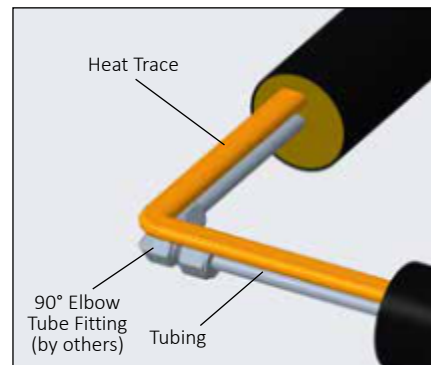

3. Cut 13 mm (1/2") off ends of tubing and make 90° elbow tube fitting connections (fitting provided by others) per manufacturer's specifications.

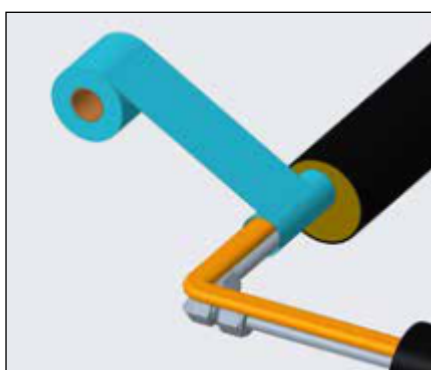

4. Wrap tube (and heat trace) with 1 pass of reflective tape (25% overlap).

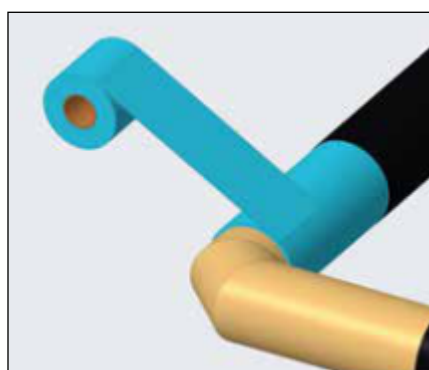

5. Wrap with 3 passes of glass fiber tape (50% overlap), or until fiber tape is equal to original bundle insulation thickness. Complete with an additional pass of heat reflective tape.

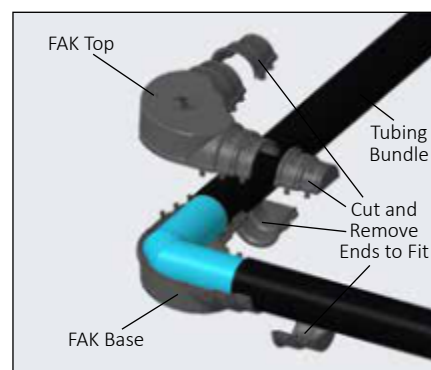

6. Using the dimensions on the splice covers, locate the correct size, ensuring a snug fit. Identify the correct cut line and cut top and bottom of splice connectors.

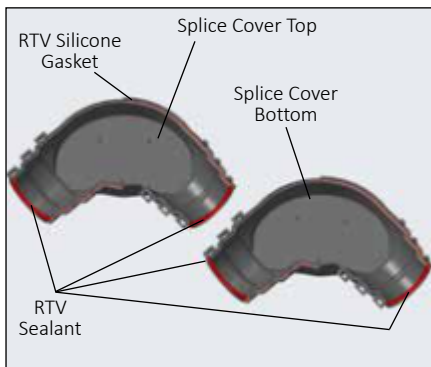

7. Install the Silicone Gasket (cut off excess). Apply RTV Sealant to both halves.

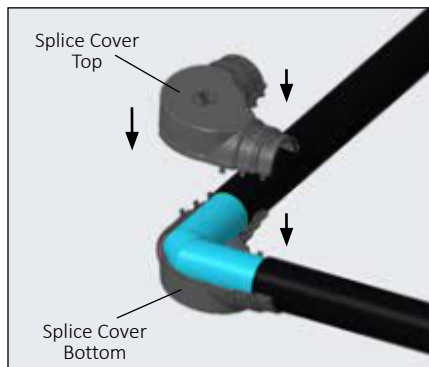

8. Fit tubing bundle to bottom half of cover and install top half. Snap both halves together firmly. Inspect ends of tubing splice cover for snug fit. Apply additional RTV sealant where needed.

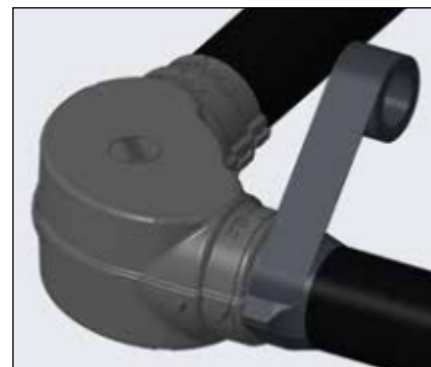

9. Apply Self-Vulcanizing Tape around bundle jacket and work up over FAK ends.



10. Completed FAK-2/2L kit.

